



# GEARED HEAD DRILL / MILL MACHINE



# INSTRUCTION MANUAL



EYE PROTECTION  
REQUIRED



HEARING PROTECTION  
REQUIRED



NEVER PLACE  
FINGERS NEAR  
CUTTING AREA



LINE VOLTAGE  
PRESENT



BEWARE OF  
ROTATING  
MACHINE PARTS

READ CAREFULLY AND UNDERSTAND THESE INSTRUCTIONS BEFORE USE.

## **LIMITED WARRANTY**

Industrial Tool & Machinery Sales (hereinafter referred to as ITMS) will, within twelve (12) months from the original date of purchase, repair or replace any goods found to be defective in materials or workmanship.

This warranty is void if the item has been damaged by accident, neglect, improper service or other causes not arising out of defects in materials or workmanship. This warranty does not apply to machines and/or components which have been altered, changed, or modified in any way, or subjected to overloading or use beyond recommended capacities and specifications. Worn componentry due to normal wear and tear is not a warranty claim. Goods returned defective shall be returned prepaid freight to ITMS or agreed repair agent, which shall be the buyer's sole and exclusive remedy for defective goods. ITMS accepts no additional liability pursuant to this guarantee for the costs of travelling or transportation of the product or parts to and from ITMS or the service agent or dealer, such costs are not included in this warranty.

The manufacturer reserves the right to make improvements and modifications to design without prior notice.

### ***Imported & Distributed By***

Industrial Tool & Machinery Sales  
18 Business St, Yatala, QLD 4207  
PH: 07 3287 1114 FX: 07 3287 1115

sales@industrialtool.com.au  
www.industrialtool.com.au

## **PRIOR TO OPERATION**

1. Power source; ensure that the power source to be used conforms to the power requirements specified on the name plate.
2. Power switch; ensure that the power switch is in the OFF position before any power is supplied to the machine.
3. Extension cord; when an extension cord must be used, ensure it is of sufficient thickness and rated capacity, and kept in the shortest length possible while remaining practical.

## **SAFETY PRECAUTIONS**

Warning! When using electric tools basic safety precautions should always be followed to reduce the risk of fire, electric shock and personal injury, including but not limited to the following.

### ***Safety - Environment***

1. Keep work area clean. Cluttered areas and benches invite injury.
2. Keep children & unauthorised persons away from the tool. Keep tool in work area with authorised trained personnel to use machine.
3. Power tools must be used in dry areas only. When using power tools outdoors, use suitable extension cord.

### **Safety - Personal**

1. Dress properly, do not wear loose clothing or jewellery, they can invite personal injury. Always cover long hair.

2. When operating power tools suitable personal protective equipment must be worn where necessary, including, but not restricted to eye, ear, respiratory and foot protection.

3. Stay alert, do not use power tools when tired or under the influence of alcohol, drugs or medicine as injury may occur.

### **Safety - Operation**

1. Secure the work in the vice. Do not hold material by hand.

2. Keep proper footing and balance at all times when using tool.

3. Keep hands away from cutting area while machine is in operation.

4. Guards should be in place and in working order. Remove adjusting keys and wrenches before turning on.

4. Ensure cutting tool is correctly secured into machine before operation.

### **Safety - After Use**

1. Disconnect machine from power when not in use.

2. Store machine in a dry place, well out of reach of children.

## **MACHINE OPERATION**



**FIGURE 1**



**FIGURE 2**

### **CHANGING THE GEAR BOX OIL**

Place a bucket to catch the oil onto the work table, then remove the oil drain socket head bolt located within the drill head as shown in Figure 1, and allow the oil to drain from the opening completely. Then replace & tighten the oil drain socket head bolt into it's original position. Remove the oil filler bolt shown in figure 2, fill the oil in the gear box with standard 80weight gear oil until the oil level reaches the middle of oil fluid level indicator glass. Then replace and tighten the bolt.

## **SETUP**

### **1. Adjustment of head**

(a) To raise and lower the head, loosen the nuts located on the right side of the column bracket. Turn the crank on the left side of the column bracket until desired head position is reached.

(b) Head may be rotated 360° by loosening the same nuts mentioned above. Adjust the head to the desired angle, then tighten nuts.

### **2. Adjustment of the lifting table**

(a) Loosen the locking handles positioned on the left side of the table bracket, turn the crank to move the lifting table up and down along the column. Once desired height is reached, tighten the handles to prevent the table from falling.

(b) When working with very large items, loosen the locking handles, rotate the work table 180°, then tighten the handles, and place the item being drilled on the base.

## **CLEANING**

**1.** Your machine has been coated with a heavy grease to protect it in shipping. This coating should be completely removed before operating the machine. Commercial degreaser, kerosene or similar solvent may be used to remove the grease from the machine, but avoid getting solvent on belts or other rubber parts.

**2.** After cleaning, coat all bare material with a light lubrication. Lubricate all points with a medium consistency machine oil.

## **LUBRICATION**

All ball bearings in your mill/drill are sealed for life, requiring no lubrication. Points requiring lubrication are:

**1.** Internal spline drive assembly. Keep this area well lubricated with a good grade grease, insert grease in the hole at the top of spindle pulley spline driver, lube twice yearly.

**2.** A light film of oil applied to the quill and column will reduce wear, prevent rust, and assure ease of operation.

**3.** Quill return spring should be oiled (sae 20) once yearly. Remove cover plate and apply oil with squirt can or small brush.

**4. IMPORTANT:** The gear box should be oiled with a lubricant such as sae 68 oil. **CHANGE OIL ONCE A YEAR.**

**5.** Apply lubricant to quill pinion every 90 days. **NOTE:** use extreme care when performing this operation and keep hands clear of pinch points. When using paraffin bar, do this only by turning the sheaves by hand. Do not apply with motor running.

## **CARE & PRECAUTIONS**

### **1. Before Operation**

(a) Fill the lubricant

(b) In order to maintain accuracy, the table must be free from dust and oil deposits.

(c) Check to see that the cutting tools are correctly located and the workpiece is clamped firmly.

### **2. After Operation**

(a) Turn off the electric switches

(b) Clean the machine and coat it with lubricant.

(c) Cover the machine with cloth to keep out the dust.

# MACHINE PARTS - BASE

ITEM	QTY	PART #	DESCRIPTION
1	1	10002/40H	base
2	1	10001/40H	column
3	1	10003/40H	lifting table
4	1	10005/40H	slip saddle
5	1	10004/40H	work table
6	1	10016/40H	elevating body
7	1	10014/40	column lid
8	1	10012/40H	locked guide ring
9	1	10014/40H	up rack
10	1	10015/40H	low rack
11	1	10011/40H	guide ring
12	1	10013/40H	fixed ring
13	1	10006/40H	gib strip
14	1	10007/40H	gib strip
15	2	10106/40	adjust screw
16	1	10203/40	guide screw nut
17	1	10202/40	guide screw
18	1	10021/40	guide screw support
19	1	10020/40	right support
20	1	10019/40	left support
21	4		bearing 51103
22	1	10008/40H	table screw

ITEM	QTY	PART #	DESCRIPTION
23	1	10009/40H	base screw
24	2	10102/40H	dial clutch
25	1	10110/40	left clutch
26	2	10111/40	graduation plate
27	3	10301/40	handwheel
28	3	20305-2B/40	screw
29	3	20305-1B/40	turn handle
30	3		adjust handle
31	5		oil cup 8
32	3		pin 5X35
33	2	10107/40	screw
34	1	10105/40	fixed block
35	2		screw M8X16
36	1		screw M5X12
37	1		screw M8X45
38	1		screw M5X16
39	8		screw M8X20
40	4		bolt M16X50
41	3		screw M10X20
42	3		screw M10X20
43	1		screw M10X40
44	2		bolt M16X190

ITEM	QTY	PART #	DESCRIPTION
45	3		washer 16
46	2		nut M16
47	2		bolt M12X16
48	2		washer 12
49	2		washer 12
50	6		pin 8X30
51	2	10017/40	bracket
52	2	10112/40	worm shaft
53	2	10113/40	small shaft
54	2		helical gear
55	2	10201/40	washer
56	2	10018/40	rock handle
57	4		retaining ring
58	8		screw M6X25
59	2		turn handle
60	1		screw M8X12
61	2	10109/40	fixed block support
62	2		nut M6
63	2		screw M6X16
64	1		degree meter
65	1		washer 16

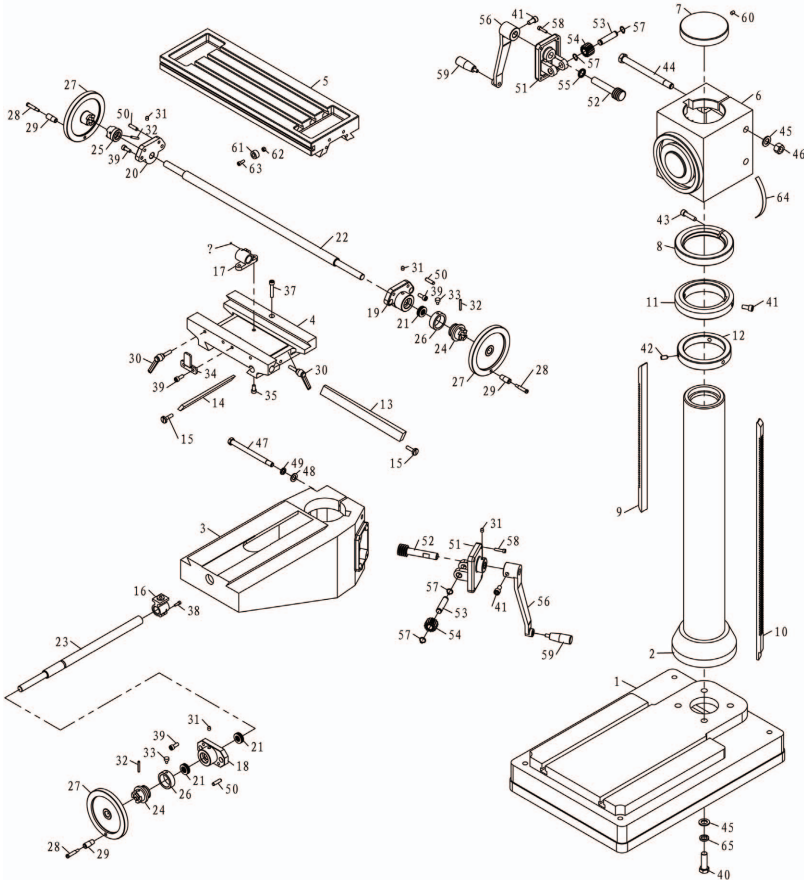

# MACHINE PARTS - HEAD

ITEM	QTY	PART #	DESCRIPTION
1	1	20010B	head body
2	1	20011B	head body cover
3	2		retaining ring
4	2		retaining ring
5	1	20018B	airtight base
6	2		airtight ring
7	1		motor
8	1		screw
9	1		washer
10	1	20201	plate
11	1	20304-1B	arbor bolt cover
12	1	20304-2B	arbor bolt cover base
13	1		screw
14	1		pin
15	1	20025B	joint
16	1	20026B	sleeve
17	1	20027B	nut
18	1		bolt
19	2	20020B	cap
20	2	20307B	speed lever
21	2		pin
22	1		oil plug
23	1		screw
24	1		screw
25	1		oil pointer
26	1	20105B	shaft
27	1	20105-1-B	gear
28	3		bearing
29	3		bearing
30	1		key
31	1	20106B	shaft
32	1	20108-B	gear
33	1	20110-1-B	gear
34	1	20111-B	gear
35	1	20106-1-B	gear
36	4		bearing
37	1		key
38	1		key
39	2		ball
40	1		spring
40/1	1		spring
41	2		retaining ring
42	1		key
43	4		screw
44	1	20107B	shaft
45	1	20109-B	gear
46	1	20110-2-B	gear
47	1	20112-B	gear
48	1	20113-B	gear
49	1		gear
50	1		key
52	1		key
53	1	20019	spindle sleeve
54	1	20104B	spindle
55	1		bearing
56	1		bearing
57	1	20114-B	splined sleeve
58	1	20116-B	gear

ITEM	QTY	PART #	DESCRIPTION
59	1		retaining ring
60	1	20012	feed base
61	1	20128	support base
62	1	20129	nut
63	1	20130	knob
64	1	20131	graduated rod
65	1	20021	fixed bolt
66	1	20132	scale board
67	1		lock washer
68	1		lock nut
69	1	20308	rubber washer
70	1		screw
71	1		split pin
72	1		bolt
73	1	20024B	separating ring
74	1	20133B	oil tight cover
75	1	62*42*12	air tight
76	1		pin
77	1	20015	worm wheel box
78	1	20119	worm shaft
79	1	20302	worm cover
80	1		retaining ring
81	1	20120	separating ring
82	1	20016	worm wheel
83	1	20117	pinion shaft
84	1	20013	handle body
85	1	20118	spring base
86	1	20123	spring cap
87	1	20122	spring plate
88	1	20303	big ripple handle
90	1	20017	graduated plate
91	1	20121B	handle rod
92	1	20301B	handle ball
93	1	20306B	handle wheel
94	1	20305-1B	turn handle
95	1	20305-2B	screw
96	1		screw
97	1	20102	washer
98	1		bolt
99	1		screw
100	1		screw
101	2		pin
102	1		key
104	2		screw
105	1	20124B	fixed bolt
106	1	20203B	fixed tight block
107	1	20202B	fixed tight block
108	1		adjust handle
109	1	20125B	lever shaft
110	1	20022-1B	lever
111	1	20204-2B	lever bracket
112	2		retaining ring
113	2		screw
114	2	20204-3B	lever rod
115	2		oil seal
116	1	20126B	long lever shaft
117	1	20204-1B	lever bracket
118	1	20022-2B	lever

# MACHINE PARTS - HEAD

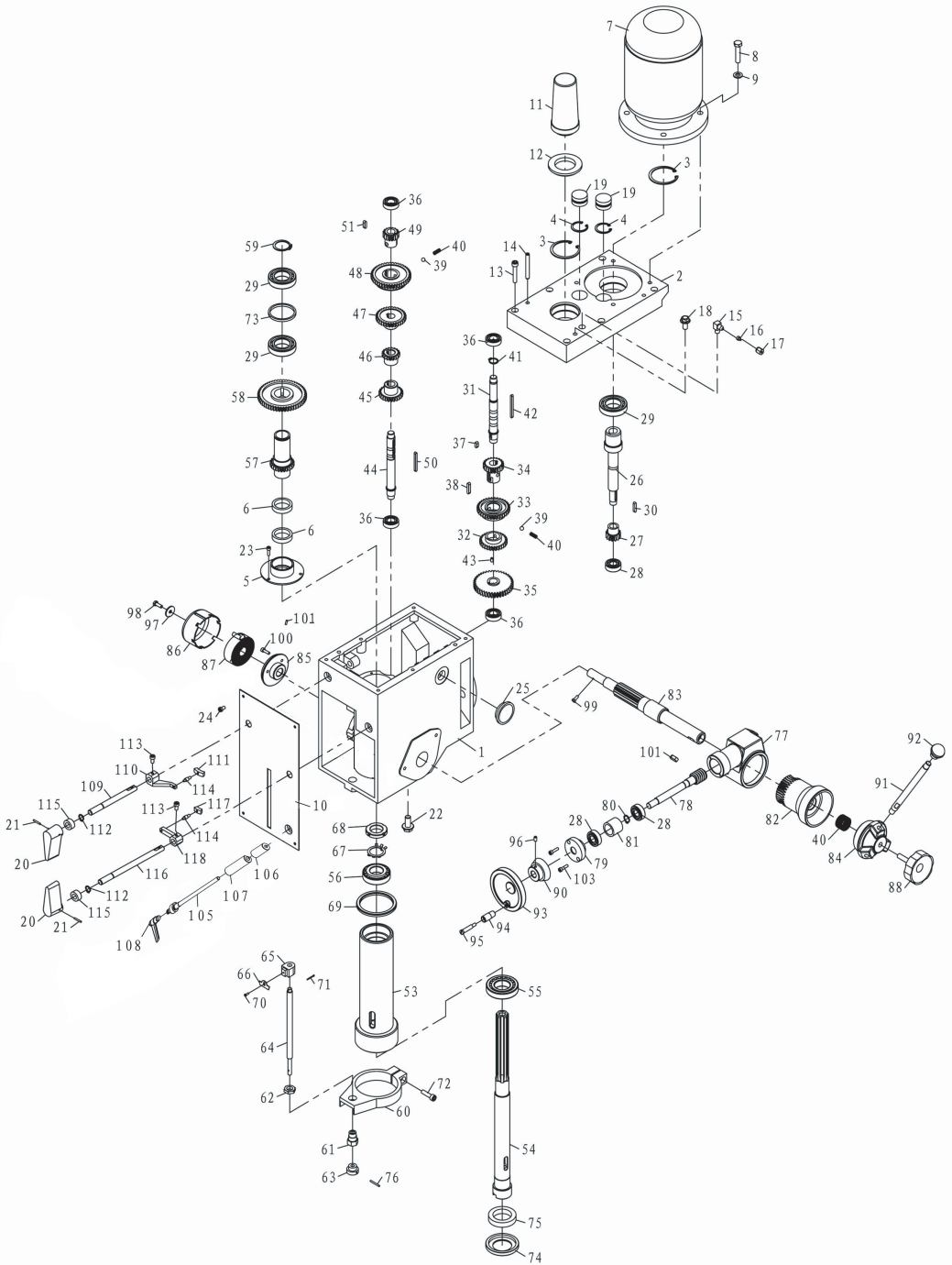

# SPECIFICATIONS

SPECIFICATIONS	TGMD400
<b>Description</b>	Geared Head Drilling Machine
<b>Max Drilling Capacity</b>	40mm
<b>Spindle Taper</b>	4MT
<b>Spindle nose to base</b>	1180mm
<b>Spindle nose to Table</b>	715mm
<b>Spindle to Column</b>	272.5mm
<b>Diameter of column</b>	115mm
<b>Spindle Travel</b>	120mm
<b>Swing</b>	660mm
<b>Head Swivel</b>	90° Left & Right
<b>Spindle Speeds (rpm)</b>	75, 170, 280, 540, 960, 1600
<b>Table Dimensions</b>	540 x 470mm
<b>Overall height</b>	1770mm
<b>Base Dimensions</b>	650 x 450mm
<b>N.W. / G.W.</b>	320 / 370kg
<b>Shipping Dimensions</b>	740 x 720 x 1830mm