

HOLEMAKER 35 PNEUMATIC

Holemaker Portable Magnetic Drilling Machine

OPERATOR'S MANUAL

WARNING!

BEFORE USE, ENSURE EVERYONE USING THIS MACHINE READS AND UNDERSTANDS ALL SAFETY AND OPERATING INSTRUCTIONS IN THIS MANUAL .



EYE PROTECTION
REQUIRED



HEARING PROTECTION
REQUIRED



NEVER PLACE
FINGERS NEAR
CUTTING AREA OR
MACHINE ARBOR

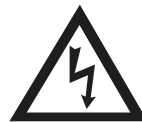

LINE VOLTAGE
PRESENT



BEWARE OF
ROTATING
MACHINE PARTS

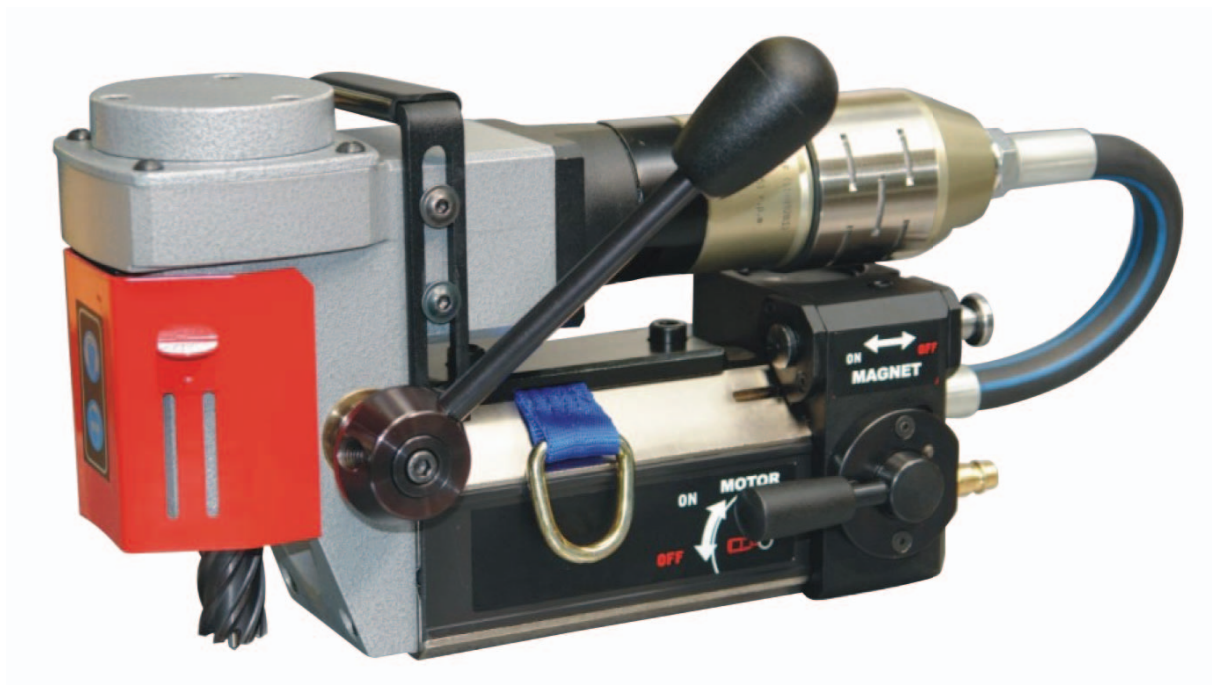

Serial # _____

Date of Purchase _____

Holemaker 35 Pneumatic Magnetic Drilling Machine

Congratulations on the purchase of your Holemaker 35 Pneumatic magnetic drilling machine. Holemaker drilling machines are designed to deliver fast, efficient hole drilling performance in portable applications.

TABLE OF CONTENTS

Important Safety Instructions	3-4
Technical Data	5
Special Instructions	6
Contents of Package	6
Machine Operation	6 - 8
Maintenance and Service	9
Basic Troubleshooting	10
Machine Parts Breakdown.....	11 - 20

LIMITED WARRANTY

Industrial Tool & Machinery Sales (hereinafter referred to as ITMS) will, within twelve (12) months from the original date of purchase, repair or replace any goods found to be defective in materials or workmanship. This warranty is void if the item has been damaged by accident, neglect, improper service or other causes not arising out of defects in materials or workmanship. This warranty does not apply to machines and/or components which have been altered, changed, or modified in any way, or subjected to overloading or use beyond recommended capacities and specifications. Worn componentry due to normal wear and tear is not a warranty claim. Goods returned defective shall be returned prepaid freight to ITMS or agreed repair agent, which shall be the buyer's sole and exclusive remedy for defective goods. ITMS accepts no additional liability pursuant to this guarantee for the costs of travelling or transportation of the product or parts to and from ITMS or the service agent or dealer, such costs are not included in this warranty.

THE MANUFACTURER RESERVES THE RIGHT TO MAKE IMPROVEMENTS AND MODIFICATIONS TO DESIGN WITHOUT PRIOR NOTICE.

Imported And Distributed By

INDUSTRIAL TOOL & MACHINERY SALES

18 BUSINESS ST, YATALA, QLD AUSTRALIA 4207

PHONE 07 3287 1114 FAX 07 3287 1115

sales@industrialtool.com.au www.industrialtool.com.au

IMPORTANT SAFETY INSTRUCTIONS



READ AND SAVE ALL INSTRUCTIONS FOR FUTURE REFERENCE.

1. Keep Work Area Clean
 - Cluttered areas and benches increase risk of injuries.
2. Consider Work Area Environment
 - Keep work area well lit.
 - Do not use tool in presence of flammable liquids or gases.
3. Check the state of the air lines, connections and machine before beginning operation
4. Ensure the drill is powered by cleaned and oiled air
5. Do not allow the drill to be submerged in water, or exposed to moisture
6. Keep Children Away
 - Do not let visitors contact tool or air supply
 - All visitors should be kept away from work area.
7. Store Idle Tools
 - When not in use, tools should be stored in a dry, high and locked-up place, out of reach of children.
8. Do Not Force Tool
 - It will do the job better and safer at the rate for which it was intended.
9. Use Right Tool
 - Do not force a small tool or attachment to do the job of a heavy-duty tool.
 - Do not use tool for unintended purpose. For example: Do not use a circular saw for cutting tree limbs or logs.
10. Dress Properly
 - Do not wear loose clothing or jewellery. They can be caught in moving parts.
 - Rubber gloves and non-skid footwear are recommended when working outdoors.
 - Wear protective hair covering to contain long hair.
 - Always wear safety glasses
 - Use face or dust mask if necessary
 - Use hearing protection
11. Do Not Abuse Tool
 - Never carry tool the air hose
 - Keep tool and air supply hose away from heat, oil and sharp edges.
12. Do Not Overreach
 - Keep proper footing and balance at all times.

IMPORTANT SAFETY INSTRUCTIONS

12. Maintain Tools With Care
 - Keep tools sharp and clean for better and safer performance.
 - Follow instructions for lubricating and changing accessories.
 - Inspect tool periodically and if damaged, have repaired by authorized service facility.
 - Inspect air supply hose periodically and replace if damaged.
 - Keep handles dry, clean, and free from oil and grease.
13. Disconnect Tools
 - Unplug from air supply when not in use, before servicing, and when changing accessories, such as cutters.
14. Remove Adjusting Keys And Wrenches
 - Form habit of checking to see that keys and adjusting wrenches are removed from tool before turning it on.
15. Avoid Unintentional Starting
 - Do not carry a plugged-in tool. Always disconnect from air supply before moving.
 - Be sure switches are off before connecting to the air supply
16. Stay Alert
 - Watch what you are doing. Use common sense. Do not operate tool when you are tired.
 - Do not use when taking medications that may cause drowsiness.
17. Check Damaged Parts
 - Before further use of the tool, any damaged parts should be repaired and performance verified prior to operation.
 - Check alignment of moving parts, binding of parts, breakage of parts, mounting, and any other conditions that may affect its operation. Any part that is damaged should be properly repaired or replaced by an authorized service center.
 - Do not use this tool if switches do not turn it on and off. Have defective switches replaced by authorized service center.
18. Use Cutter Guard
 - Always use cutter guard supplied with machine to reduce the risk of injury. (refer fig. 1)

Fig. 1



TECHNICAL DATA

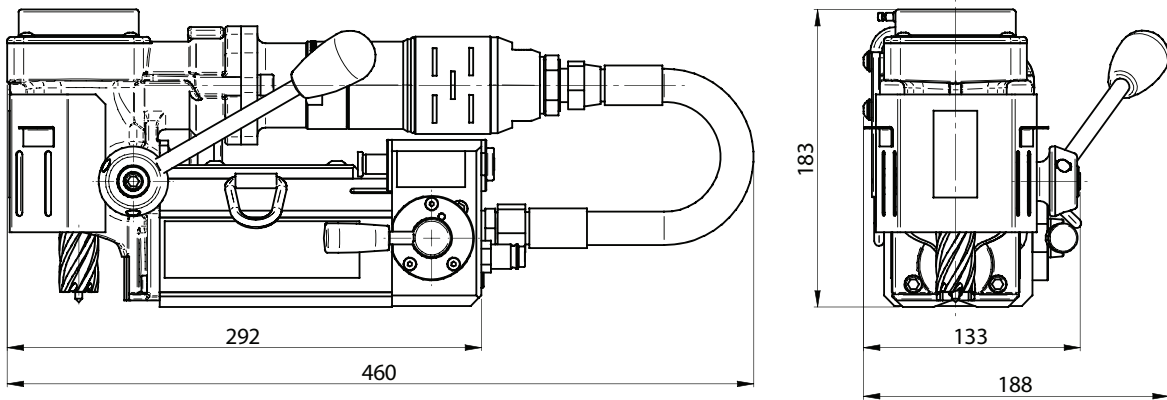

Operating pressure	85 PSI
Air consumption	1400 l/min
Motor Power	800Watt
Arbor size	3/4" Weldon /19,05 mm/
Hole capacity with slugger cutter	35mm (1.38 in)
Maximum drilling depth	25mm (0.98 in)
Stroke	39mm (1.54 in)
Magnet force on 25mm Plate	6,500 N
Free Speed	500 rpm
Load speed	240 rpm
Magnetic base	80x80x143 mm
Weight	14kg
Noise level	above 70 dB
Working temperature range	-20°C /+ 40°C

The compressed-air motor used in the HMP35AD drill is certified ATEX II2G/D C IIC T6;T4 and meets the requirements for use in areas with a risk of explosion.

SPECIAL INSTRUCTIONS

1. Read and follow operator's manual thoroughly.
2. DO NOT touch rotating cutter or parts.
3. Always stop machine completely and unplug from air supply before changing cutters, clearing swarf, refilling lubrication or performing adjustments.
4. Never wear loose clothing or gloves when working near cutting area or machine arbor.
5. Always wear eye protection. Any tool can shatter.
6. Always use safety chain or strap provided with machine.
7. Always use proper tooling. Keep cutters securely fastened.
8. DO NOT use dull or broken cutters.
9. Beware of ejected slugs at end of cut. They become HOT during the cut.
10. Keep all safety features functioning and working properly.
11. Keep bottom of magnet burr free and clear of chips and debris.
12. Use only authorized service centers for repairs.

Remove all contents from packaging and inspect to ensure no damage was incurred during shipping. Your Holemaker package should include the following:

DESCRIPTION	QTY
HOLEMAKER HMP35AD MACHINE	1
METAL CARRY CASE	1
SAFETY CHAIN WITH CLIP	1
HEX WRENCH 4	1
HEX WRENCH 4	1
FEED HANDLE	1
COOLANT BOTTLE ASSEMBLY	1
OPERATORS MANUAL	1

WHAT YOU SHOULD KNOW BEFORE YOU DRILL

1. Type of material to be drilled, Brinnell or Rockwell hardness, material thickness and position should all be determined to ensure proper selection of cutting tools.
2. Remove any excessive mill scale or rust from surface to be drilled.
3. When drilling thin materials, it is recommended that you place a steel plate under the work piece and Holemaker magnet area to increase magnetic holding force.
4. Material that has been flame cut may become heat treated and therefore difficult to drill. Avoid drilling near such areas whenever possible.
5. Special cutter lubricant is available for using the Holemaker and annular cutters in the horizontal position. Consult your distributor for more information.

 The Holemaker HMP35AD is not designed for use on steel thinner than 3/8" or 10mm, as the magnet's adhesive power would be significantly reduced which can cause machine failure or individual injury.

 Never use the pneumatic hose running from the motor to the machine's frame as a lifting handle.

START UP AND OPERATION

CAUTION: READ THE WHOLE INSTRUCTIONS MANUAL BEFORE ATTEMPTING TO START UP

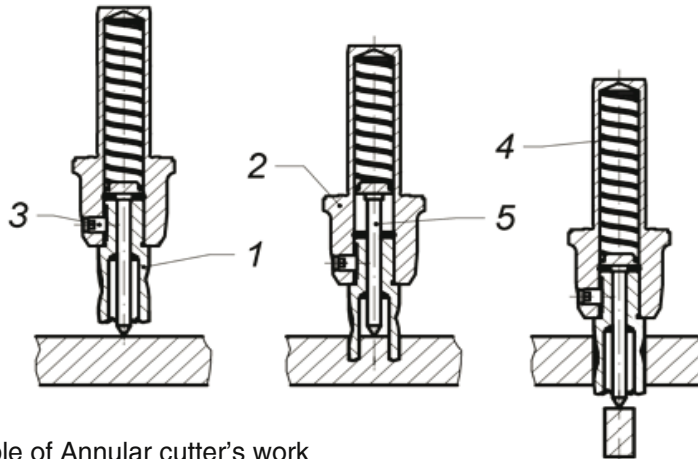

Principle of Annular cutter's work

This drilling machine's spindle has a 19mm Weldon Shank type and is specifically designed for use with Annular cutters.

Annular cutter (1) is located inside arbor body (2) and is fastened with grub screws (3). When fastening the cutter in the arbour, ensure that the grub screws are firmly tightened to avoid them coming loose during operation. It is important to position the cutter in relation to the arbour in such a way that fixing flats on the cutter shank are positioned opposite to the grub screws (3). Both grub screws(3) should be used to fasten the cutter. The Pilot Pin (5) is located inside the cutter to easily position the annular cutter over centre of a planned hole. During drilling as the cutter goes into the material, the pilot pin moves back into the arbour body and pressurizes the discharge spring (4). That spring ejects the slug which is a by-product of drilling the hole with a centre free cutter.

Before you cut

Steel elements of this machine are coated with a layer of lubricant for the period of storage and transport, and must be cleaned off prior to their usage.

Before positioning the machine on work piece always make sure that:

- work piece is made of ferrous material
- thickness of work piece is adequate for secure magnetic adhesion (mild steel - 10mm is recommended)
- Ensure no part of magnet overhangs the steel workpiece
- surface of steel under the magnet is flat
- wipe, brush or sand down clean surface where you intended to place the drilling machine, so that you remove rust, paint, dirt etc which would reduce adhesive power of the electromagnetic base.

Install annular cutter in the machine before plugging it into air supply

Always make sure prior to use that the machine is secured from falling down with a chain/strap.

Cutting

- Choose a suitable lubricating fluid and fill the coolant tank.

The cooling system is an integral part of the machine and should always be used.

Warning: The cooling system works gravitationally, therefore it can be used only when in vertical position of the drilling machine. In other positions, a cutting paste should be used

- Check workings of cooling system. Open the coolant tank's tap and apply pressure on the pilot by turning spokes counter clockwise. As the pilot starts to sink into the cutter, cooling liquid should start to run down the groove in pilot pin. If there is no liquid flowing down, check if the tap is fully opened. It may take a few seconds for cooling liquid to fill the whole system.

In order to start the machine:

- Make sure that the motor connection lever is in the OFF position. turn the magnet switch to the ON position. turn the motor connection lever to the ON position.
- turning the motor connection lever to the OFF position will cause the motor to stop running. The magnetic base will still be on.
- in order to change the drilling location, the magnet switch should be set to the OFF position after the drive has been stopped.

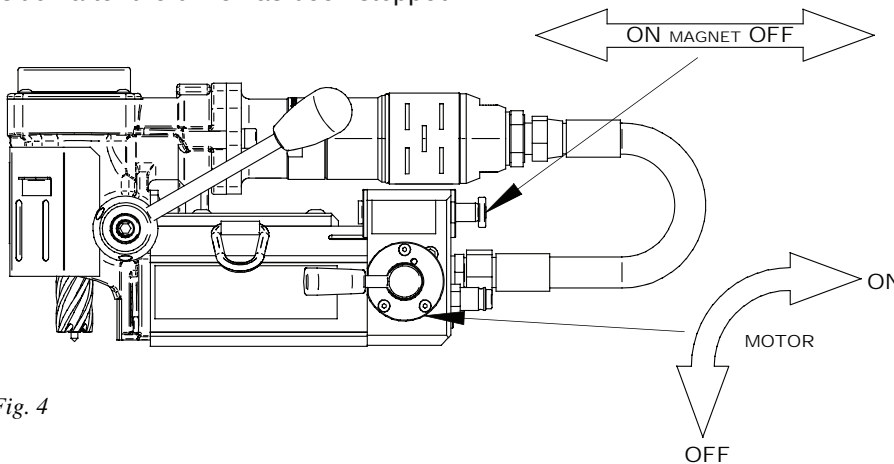

Fig. 4

Making a hole with an annular cutter should ideally be done in one pass. Do not peck drill.

WARNING: When the annular cutter goes through the material the slug can be pushed out often with considerable strength. Pay attention to avoid injury.

- After a hole is made the cutter should be retracted and both the motor and the electromagnet should be switched OFF.
- When work with the machine is finished the machine should be disconnected from the air supply, the machine should be cleaned up from swarf, coolant etc. and the cutter should be removed and cleaned.

MAINTENANCE AND SERVICE

- Regularly grease the pinion and the teeth on the pinole sleeve.
- All component parts should be cleaned and maintained with a thin oil film.
- Use only clean, detergent-free oil with a density compliant with SAE 10 (90SSU) or lower.
- When working with a pneumatic motor, it is necessary to use an air preparation unit.

ATTENTION: The pneumatic motor's guarantee is invalid when damages arise from pollution in the air feed or lack of lubrication.

- Lubrication of the pneumatic motor.
- Direct servicing is not necessary when drill usage is normal.
- It is necessary to use an air preparation unit in the air feed system.
- Inspections and servicing of the air preparation unit should be carried out as needed depending on the air pollution level. Clean the filter, dry out the dehydrator, and maintain an oil level with drips every 2-5 seconds.
- Oil used in the air preparation unit must have an ignition temperature higher than 260°C.
- Any type of mechanical repair of the drill should be done at a service workshop recommended by the vendor. When repairing use only original parts.

ATTENTION: The HMP35AD drill is designed to be powered by air with working pressure 4 to 6 bar /60 to 90 PSI/. Maintenance of the machine's technical parameters and its general state are strictly dependent on the cleanness and preparation of the air and proper servicing.

BASIC TROUBLESHOOTING

1. Magnetic base not holding securely
 - Material is too thin.
 - Surface of material being drilled must be free of chips, debris, rust and mill scale.
 - Does size of cutter exceed machine's rated capacity?
 - Check magnet face for unevenness, nicks and burrs.
2. Drill motor running, arbor and spindle not turning
 - Possible sheared drive train component.
3. Motor slows when drilling
 - Excessive downfeed pressure during drilling cycle will cause motor to slow
 - Does cutting tool need to be resharpened?
4. Coolant system not working
 - Dirt or debris in coolant tank.
 - Consistency of coolant mixture too thick.
 - Is correct pilot pin being used?
 - Vent hole in coolant tank lid blocked.
5. Slugs not ejecting from cutter
 - Lack of coolant causing slugs to expand in cutter bore.
 - Is correct pilot pin being used?
 - Possible broken internal arbor parts.
6. Breaking cutters
 - How is coolant being applied? Coolant must be supplied to interior of cutter.
 - Excessive feed pressure being applied when cutter initially contacts work surface.
 - Confirm material hardness.
 - Drilling stacked materials with incorrect cutter.
 - Dull cutters; dull or chipped cutting edges require excessive feed pressure, resulting in breakage.
 - Movement of machine on material - See "1. Magnetic base not holding securely"
 - Inconsistent hardness in material can cause cutter breakage
7. Oversized or rough holes
 - Insufficient coolant.
 - Excessive feed pressure.
 - Dull cutter.

ITEM	PART NUMBER	DESCRIPTION	QTY
1	SPMP3501	MAIN BODY ASSEMBLY	1
2	SPMP3502	VALVE ASSEMBLY	1
3	SPMP3503	QUILL ASSEMBLY	1
4	SPMP3504	BEVEL GEAR T=39 ASSEMBLY,	1
5	SPMP3505	GEAR BOX COVER ASSEMBLY,	1
6	SPMP3506	BEARING NUT HOLDER,	1
7	SPMP3507	SLEEVE	2
8	SPMP3508	PINION	1
9	SPMP3509	DRIVER	1
10	SPMP3510	MAIN BODY BRACKET	1
11	SPMP3511	MOTOR HOSE ASSY	1
12	SPMP3512	GEARSHFT T=11,	1
13	SPMP3513	HEAD ASSEMBLY,	1
14	SPMP3514	SPOKE HANDLE INCLUDING 35406 KNOB	1
15	SPMP3515	D-RING STRAP	1
16	SPMP3516	STRAIGHT COUPLING 1/2" - 3/8"	1
17	SPMP3517	STRAIGHT COUPLING 3/4" - 3/8"	1
18	SPMP3518	HOLDER SLEEVE	2
19	SPMP3519	HOLDER	1
20	SPMP3520	TURN ON/OFF GEAR	1
21	SPMP3521	GEAR PLUG	1
22	SPMP3522	GUARD'S SLIDE	1
23	SPMP3523	GUARD ASSEMBLY	1
25	SPMP3525	SOCKET BUTTON HEAD CAP SCREW M5	4
26	SPMP3526	SCREW M8x16	2
27	SPMP3527	SOCKET BUTTON HEAD CAP SCREW M6	2
28	SPMP3528	SCR, M4 x 16 FHSCS	3
29	SPMP3529	SCR, M6 x 12 FHSCS	2
30	SPMP3530	SPRING WASHER 6,1	2
31	SPMP3531	SPRING WASHER 8.2	2
32	SPMP3532	ROUND WASHER 6,4	2
33	SPMP3533	HEX. SOCKET BOLT M4x6	1
34	SPMP3534	HEX. SOCKET BOLT M6x20	2
35	SPMP3535	HEX. SOCKET BOLT M6x65	2
36	SPMP3536	HEX SOCKET BOLT-M8X30	2
37	SPMP3537	EXTERNALE RETAINING RING 16z	2
38	SPMP3538	EXTERNALE RETAINING RING 25z	1
39	SPMP3539	INTERNAL RETAINING RING-47W	1
40	SPMP3540	SEAL RING 80x1,3,	1
41	SPMP3541	BEARING BALL 6003	1
42	SPMP3542	BEARING, BALL 6005 ZZ	1
43	SPMP3543	AIR MOTOR	1
44	SPMP3544	SEAL, 3/4"	1
45	SPMP3545	SWITCH CONNECTOR	1
46	SPMP3546	HEX SET SCREW-M6 x 6	1
47	SPMP3547	GUARD SLEEVE	2
48	SPMP3548	LABELS, SET	1
49	SPMP3549	MAGNET BASE	1

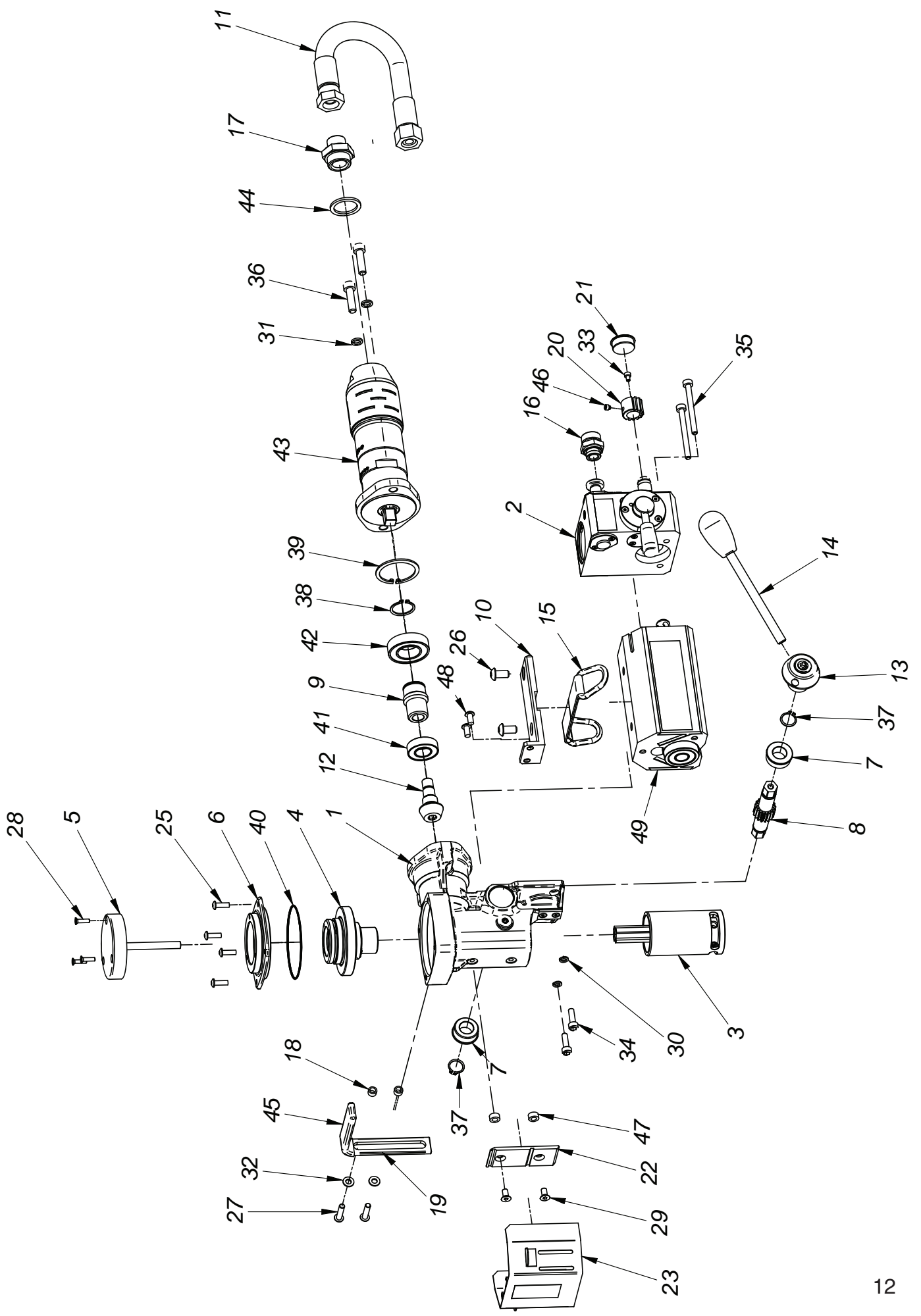

Part Number:SPMP3501		MAIN BODY ASSEMBLY	
ITEM	PART NUMBER	DESCRIPTION	QTY
1.1	SPMP350101	MAIN BODY	1
1.2	SPMP350102	BUSHING PERMAGLIDE	
1.3	SPMP350103	HEX. INSERT SCREW M8x6	1
1.4	SPMP350104	MAIN BODY PLATE	1
1.5	SPMP350105	SCR, M4 x 10 FHSCS	2

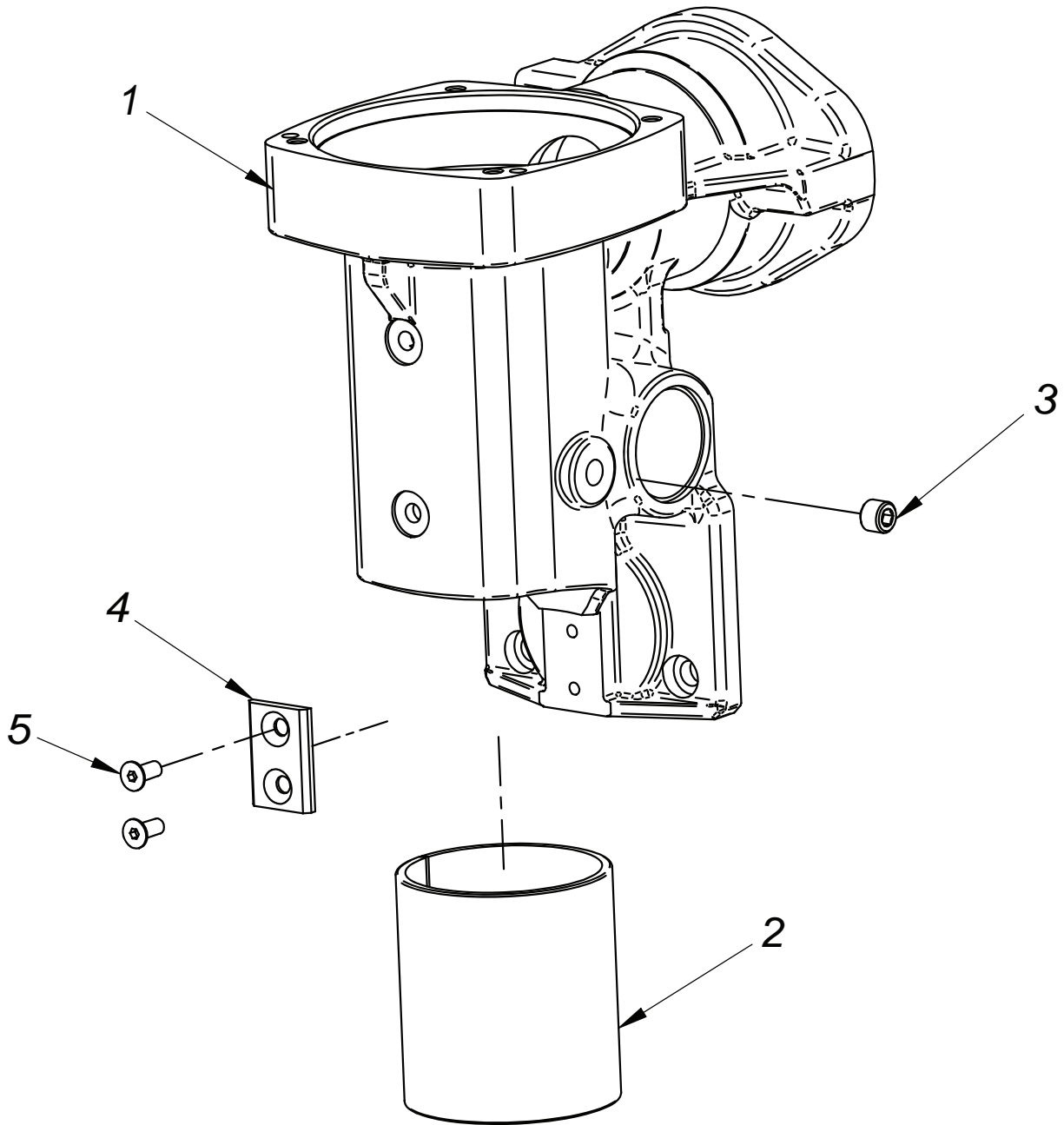

Part Number:SPMP3502		VALVE ASSEMBLY	
ITEM	PART NUMBER	DESCRIPTION	QTY
2.1	SPMP350201	VALVE HOUSING	1
2.2	SPMP350202	PISTON ASSY	1
2.3	SPMP350203	PISTON PLUG	1
2.4	SPMP350204	STOP PLUG	1
2.5	SPMP350205	LOCKING RING	1
2.6	SPMP350206	SPRING	1
2.7	SPMP350207	BALL LOCK GN 614-8-NI	1
2.8	SPMP350208	EXTERNAL RING	1
2.9	SPMP350209	HANDLE HOLDER	1
2.10	SPMP350210	WASHER	1
2.11	SPMP350211	HANDLE SHAFT	1
2.12	SPMP350212	HANDLE ASSY	1
2.13	SPMP350213	SEAL COVER	1
2.14	SPMP350214	COVER	1
2.15	SPMP350215	DIVIDING SHAFT	1
2.16	SPMP350216	SLEEVE I	1
2.17	SPMP350217	SLEEVE CENTER	2
2.18	SPMP350218	SLEEVE II	1
2.19	SPMP350219	COVER I	1
2.20	SPMP350220	COVER II	1
2.21	SPMP350221	SHAFT RING	1
2.22	SPMP350222	SCR, M3 x 8 FHSCS	8
2.23	SPMP350223	SCR, M4 x 16 FHSCS	3
2.24	SPMP350224	HEX. INSERT SCREW M5x8	1
2.25	SPMP350225	HEX. INSERT SCREW M12x8	4
2.26	SPMP350226	PIN 4x10	1
2.27	SPMP350227	EXTERNAL RETAINING RING 8z	1
2.28	SPMP350228	RETAINING RING INTERNAL 21w	1
2.29	SPMP350229	RETAINING RING INTERNAL 24w	1
2.30	SPMP350230	INTERNAL RETAINING RING-47W	1
2.31	SPMP350231	O-RING 9x2	1
2.32	SPMP350232	O-RING 15,3x2,4	1
2.33	SPMP350233	O-RING 18x2	2
2.34	SPMP350234	O-RING 42x2	1
2.35	SPMP350235	SEAL, 4x8,2x4	1
2.36	SPMP350236	SEAL U2 012x18.4	4
2.37	SPMP350237	MALE PLUG, G3/8" 10mm	1

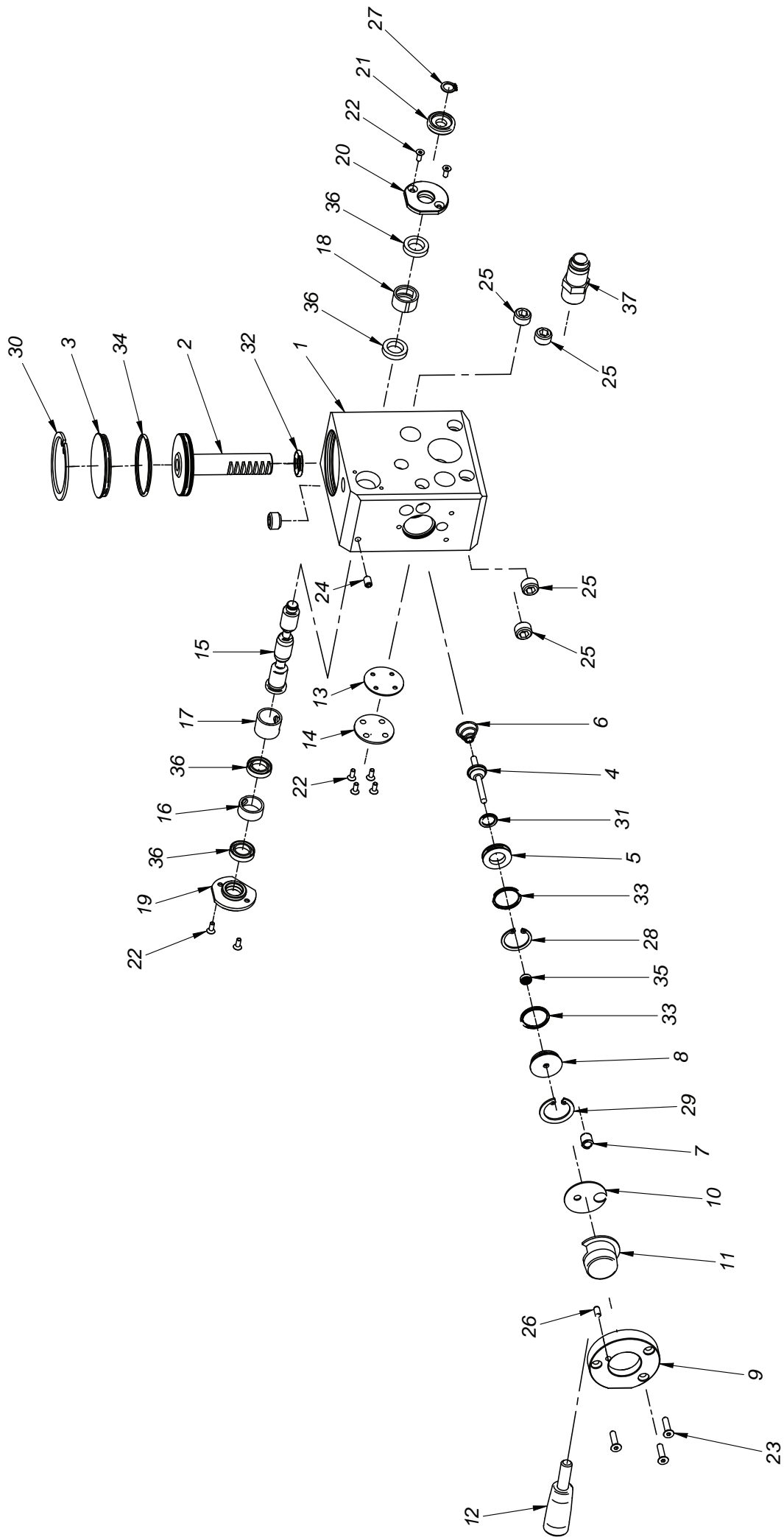

Part Number:SPMP350202		PISTON ASSY	
ITEM	PART NUMBER	DESCRIPTION	QTY
2.2.1	SPMP35020201	PISTON	1
2.2.2	SPMP35020202	PISTON GEAR RACK	1
2.2.3	SPMP35020203	O-RING 39,2x3	1

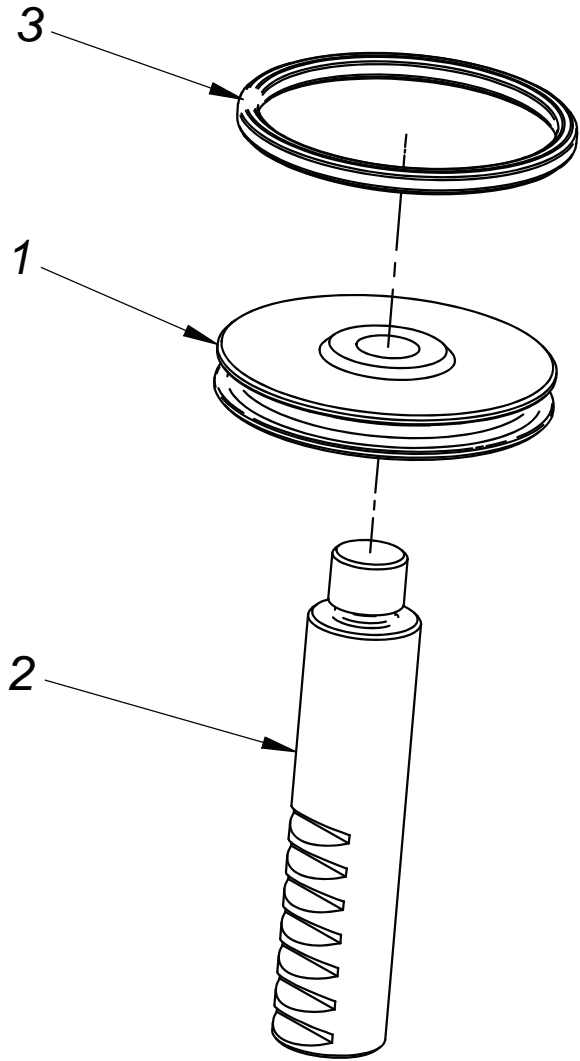

Part Number:SPMP3503		QUILL ASSEMBLY	
ITEM	PART NUMBER	DESCRIPTION	QTY
3.1	SPMP350301	QUILL CARRIER	1
3.2	SPMP350302	SPINDLE	1
3.3	SPMP350303	DISTANCE SLEEVE	1
3.4	SPMP350304	SPRING	1
3.5	SPMP350305	SEAL	1
3.6	SPMP350306	PLUNGER	1
3.7	SPMP350307	NEEDLE BEARING RHNA303720	1
3.8	SPMP350308	BEARING BALL 6004 2RS	1
3.9	SPMP350309	INTERNAL RETAINING RING 19W	1
3.10	SPMP350310	EXTERNAL RETAINING RING- 20Z	1
3.11	SPMP350311	INTERNAL RETAINING RING - 42W	1
3.12	SPMP350312	HEX SET SCREW M8x10	2
3.13	SPMP350313	SEAL RING TRK000080	2

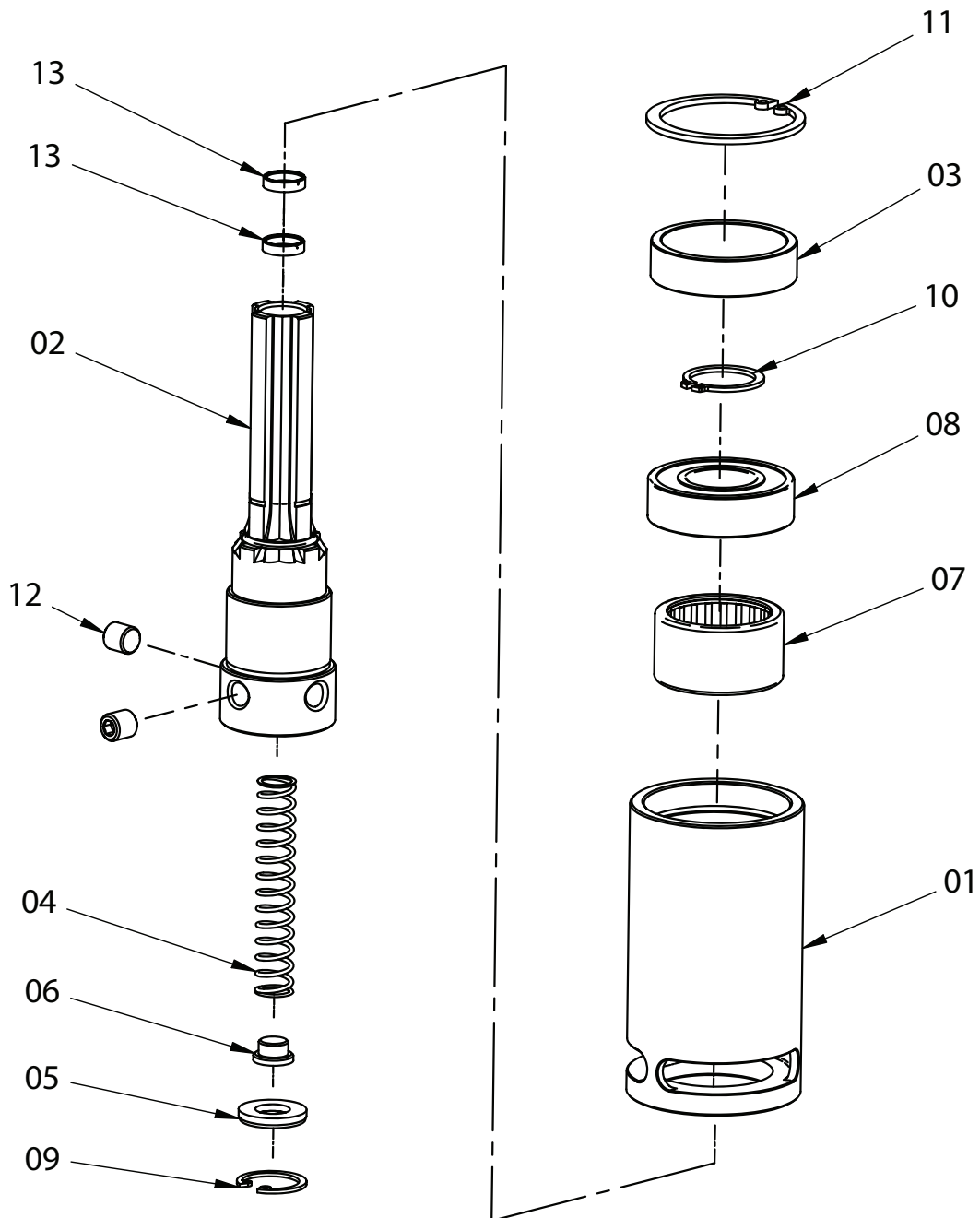

Part Number:SPMP3504		BEVEL GEAR T=39 ASSEMBLY	
ITEM	PART NUMBER	DESCRIPTION	QTY
4.1	SPMP350401	BEVEL GEAR T=39 ASSY / INCL. SLEEVE	1
4.2	SPMP350402	BEARING NUT	1
4.3	SPMP350403	BEARING BALL 61805 2RS	1
4.4	SPMP350404	EXTERNAL RETAINING RING 25Z TYPE A	1
4.5	SPMP350405	INTERNAL RETAINING RING 37W	1
4.6	SPMP350406	HEX SET SCREW M5x10	1

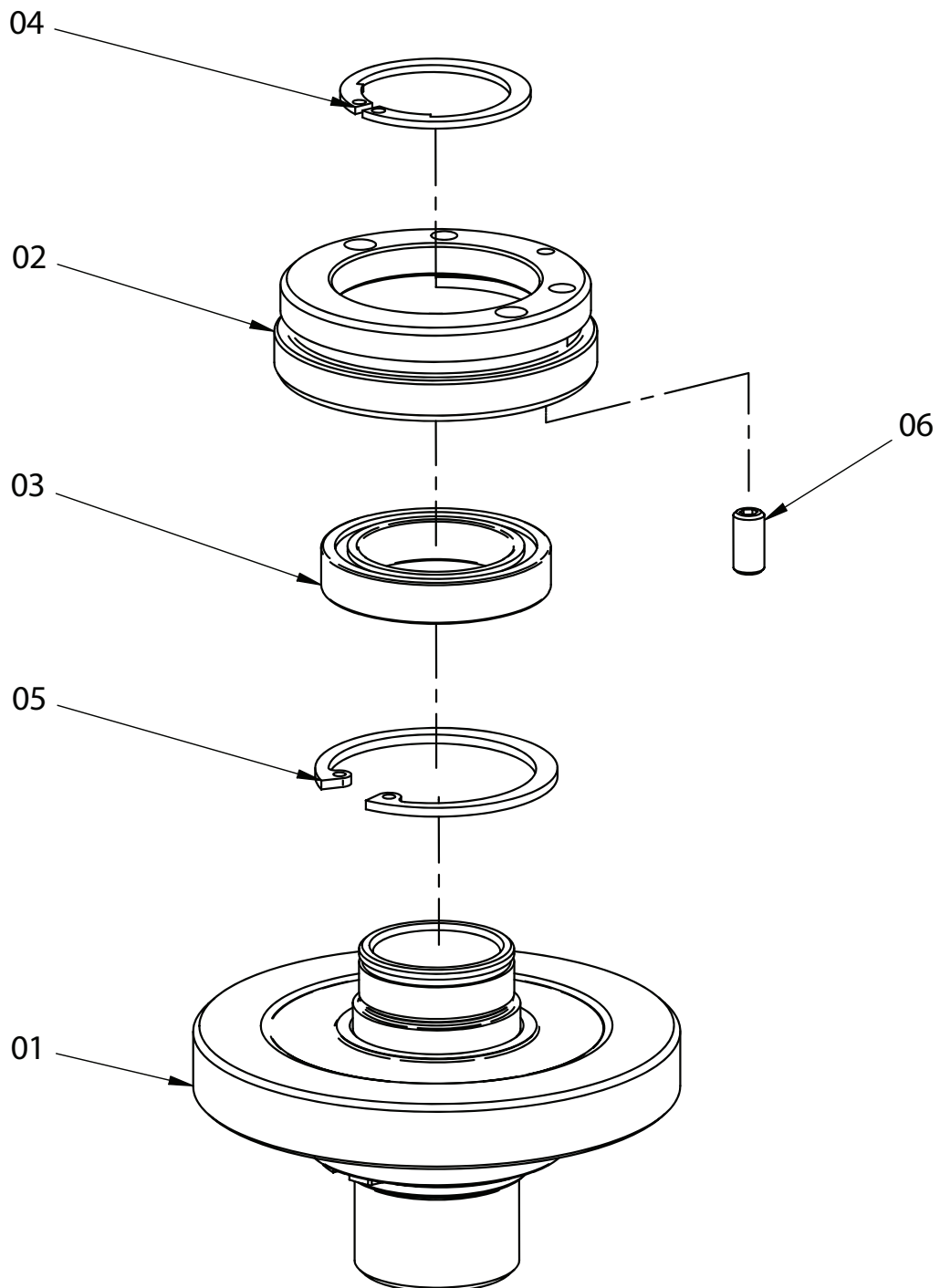

Part Number:SPMP350401		BEVEL GEAR T=39 ASSY / INCL. SLEEVE	
ITEM	PART NUMBER	DESCRIPTION	QTY
4.1.1	SPMP35040101	SLEEVE	1
4.1.2	SPMP35040102	BEVEL GEAR T=39	1
4.1.3	SPMP35040103	BEARING BALL 6806 LLU	1
4.1.4	SPMP35040104	EXTERNAL RETAINING RING 30z	1

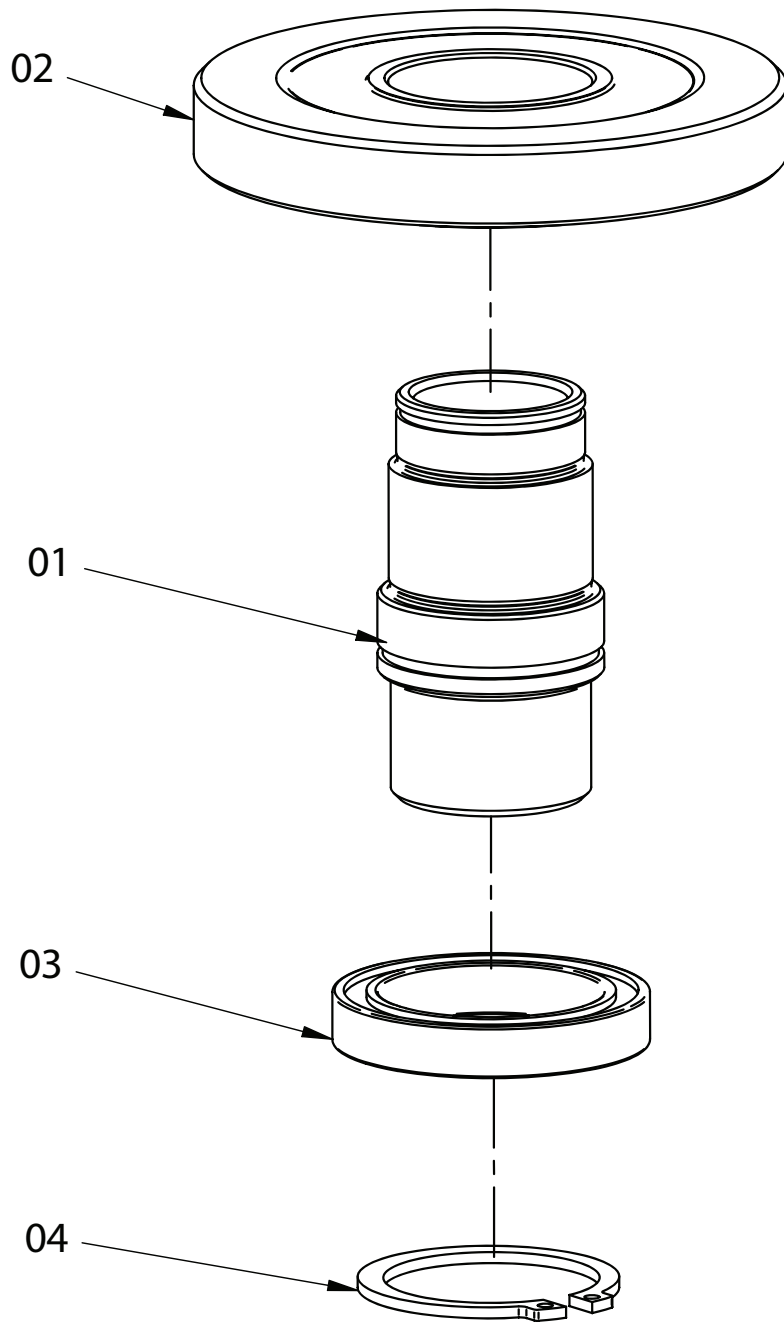

Part Number:SPMP3505		GEAR BOX COVER ASSEMBLY	
ITEM	PART NUMBER	DESCRIPTION	QTY
5.1	SPMP350501	GEAR BOX COVER	1
5.2	SPMP350502	JUMPER	1
5.3	SPMP350503	Anschlussnippel fur AMT2-H-19	1

