

Slugger® Magforce

Slugger Portable Magnetic Drilling Machine

OPERATOR'S MANUAL

⚠ WARNING!

BEFORE USE, BE SURE EVERYONE USING THIS MACHINE READS AND UNDERSTANDS ALL SAFETY AND OPERATING INSTRUCTIONS IN THIS MANUAL



EYE PROTECTION
REQUIRED



HEARING PROTECTION
REQUIRED



NEVER PLACE
FINGERS NEAR
CUTTING AREA OR
MACHINE ARBOR



LINE VOLTAGE
PRESENT



BEWARE OF
ROTATING
MACHINE PARTS

Slugger®



MODEL #06920

Serial # _____

Date of Purchase _____

Slugger Portable Magnetic Drilling Machine

Congratulations on your purchase of a Slugger portable magnetic drilling machine. Slugger drilling machines are designed to deliver fast, efficient hole drilling performance in portable applications. Please take a moment to complete and mail your product warranty registration card. Doing so will validate your machine's warranty period and ensure prompt service if needed. Thank you for selecting a Slugger product from Jancy Engineering Company.

TABLE OF CONTENTS

Important Safety Instructions	3-4
Special Instructions	5
Grounding Instructions and Extension Cords	6
Contents of Package	7
Getting Started	7
Machine Operation	8
Basic Troubleshooting	9
Regular Maintenance	10
Connection Diagram	11
Machine Frame Breakdown	11
Machine Breakdown	12
Machine Parts List	13
Armature and Field Assembly	14
Available Slugger Cutters	15

LIMITED WARRANTY

Jancy Engineering Company will, within one (1) year from the original date of purchase, repair or replace any goods found to be defective in materials or workmanship, provided the product warranty registration card has been returned to Jancy Engineering Company within thirty (30) days of purchase date. This warranty is void if the item has been damaged by accident, neglect, improper service or other causes not arising out of defects in materials or workmanship. This warranty does not apply to machines and/or components which have been altered, changed, or modified in any way, or subjected to use beyond recommended capacities and specifications. Electrical components are subject to respective manufacturers' warranties. All goods returned defective shall be returned prepaid freight to Jancy, which shall be the buyer's sole and exclusive remedy for defective goods. In no event shall Jancy Engineering be liable for loss or damage resulting directly or indirectly from the use of merchandise or from any other cause. Jancy Engineering is not liable for any costs incurred on such goods or consequential damages. No officer, employee or agent of Jancy is authorized to make oral representations of fitness or to waive any of the foregoing terms of sale and none shall be binding on Jancy.

**JANCY ENGINEERING RESERVES THE RIGHT TO MAKE
IMPROVEMENTS AND MODIFICATIONS TO DESIGN WITHOUT PRIOR NOTICE.**

IMPORTANT SAFETY INSTRUCTIONS

WARNING!

WHEN USING ELECTRIC TOOLS, BASIC SAFETY PRECAUTIONS SHOULD ALWAYS BE FOLLOWED TO REDUCE RISK OF FIRE, ELECTRIC SHOCK AND PERSONAL INJURY.

READ AND SAVE ALL INSTRUCTIONS FOR FUTURE REFERENCE.

1. **Keep Work Area Clean**
 - Cluttered areas and benches invite injuries.
2. **Consider Work Area Environment**
 - Do not expose power tools to rain.
 - Do not use power tools in damp or wet locations.
 - Keep work area well lit.
 - Do not use tool in presence of flammable liquids or gases.
3. **Guard Against Electric Shock**
 - Prevent body contact with grounded surfaces. For example: pipes, radiators, ranges and refrigerator enclosures.
4. **Keep Children Away**
 - Do not let visitors contact tool or extension cord.
 - All visitors should be kept away from work area.
5. **Store Idle Tools**
 - When not in use, tools should be stored in a dry, high and locked-up place, out of reach of children.
6. **Do Not Force Tool**
 - It will do the job better and safer at the rate for which it was intended.
7. **Use Right Tool**
 - Do not force a small tool or attachment to do the job of a heavy-duty tool.
 - Do not use tool for unintended purpose. For example: Do not use a circular saw for cutting tree limbs or logs.
8. **Dress Properly**
 - Do not wear loose clothing or jewelry. They can be caught in moving parts.
 - Non-skid footwear is recommended when working outdoors.
 - Wear protective hair covering to contain long hair.
9. **Use Safety Glasses**
 - Also use face or dust mask if cutting operation is dusty.
10. **Do Not Abuse Electrical Cord**
 - Never carry tool by cord or yank it to disconnect from receptacle.
 - Keep cord from heat, oil and sharp edges.
11. **Secure Work**
 - Use clamps or a vise to hold work. It's safer than using your hand and it frees both hands to operate tool.
12. **Do Not Overreach**
 - Keep proper footing and balance at all times.

IMPORTANT SAFETY INSTRUCTIONS

13. Maintain Tools With Care

- Keep tools sharp and clean for better and safer performance.
- Follow instructions for lubricating and changing accessories.
- Inspect tool cords periodically and if damaged, have repaired by authorized service facility.
- Inspect extension cords periodically and replace if damaged.
- Keep handles dry, clean, and free from oil and grease.

14. Disconnect Tools

- Unplug when not in use, before servicing, and when changing accessories, such as bits and cutters.

15. Remove Adjusting Keys And Wrenches

- Form habit of checking to see that keys and adjusting wrenches are removed from tool before turning it on.

16. Avoid Unintentional Starting

- Do not carry a plugged-in tool. Always disconnect from power source before moving.
- Be sure switches are off before connecting to a power source.

17. Outdoor Use Extension Cords

- When tool is used outdoors, use only extension cords intended for use outdoors and so marked.

18. Stay Alert

- Watch what you are doing. Use common sense. Do not operate tool when you are tired.
- Do not use when taking medications that may cause drowsiness.

19. Check Damaged Parts

- Before further use of the tool, a guard or other part that is damaged should be carefully checked to determine that it will operate properly and perform its intended function.
- Check alignment of moving parts, binding of parts, breakage of parts, mounting, and any other conditions that may affect its operation. A guard or other part that is damaged should be properly repaired or replaced by an authorized service center.
- Do not use this tool if switches do not turn it on and off. Have defective switches replaced by authorized service center.

SPECIAL INSTRUCTIONS

1. If you require an additional manual, please contact Jancy Engineering at (563) 391-1300 for a **FREE** copy.
2. Never place hands, fingers, gloves or clothing near cutting area or rotating machine parts.
3. Always disconnect machine from power source before changing cutters, clearing chips, refilling lubricant or performing adjustments.
4. Keep all safety features functioning and working properly.
5. Never wear loose clothing, gloves or jewelry when working near cutting area or rotating machine parts.
6. Always use eye and hearing protection.
7. Always use safety strap and chip guard provided with machine.
8. Always use proper tooling. Keep cutters securely fastened.
9. Do not use dull or broken cutters.
10. Do not use Slugger drilling machines on surfaces or materials being welded. Doing so can damage the machine's electrical components.
11. Beware of slugs ejected at end of cut. They become HOT during the cut.
12. Magnet will not hold properly on thin materials or rough and dirty surfaces.
13. Keep bottom of magnet burr free and clear of chips and debris.
14. To reduce the risk of electrical shock, do not use machine in wet or damp areas.
15. Do not remove or alter electrical panels. Use only authorized service centers for repairs.

WARNING!

DO NOT OPERATE MACHINE IF WARNING AND/OR INSTRUCTION LABELS ARE MISSING OR DAMAGED.
CONTACT JANCY ENGINEERING FOR REPLACEMENT LABELS.





SAFETY INSTRUCTIONS



- Read and follow operators manual thoroughly.
- If you can not locate your operators manual call Jancy Engineering at 563-391-1300 for a FREE copy.
- Always stop machine completely and disconnect from power source before changing cutters, performing adjustments, or servicing.
- Do not use altered, dull or broken cutters.
- Never wear loose clothing or gloves when working near cutting area or machine arbor.
- Always use provided safety strap and chip shield.
- Use proper tooling, keep cutters securely fastened.
- Magnet will not hold properly on thin materials, rough and / or dirty surfaces, keep bottom of magnet free of chips and debris.
- Keep all safety features functioning and working properly.
- Use only authorized service centers for repairs.



WARNING!

-  Always use eye protection, any tool can shatter.
-  Line voltage present. To reduce risk of electrical shock, user must read and understand instructions manual.

CAUTION

-  Always wear hearing protection.
-  Beware of ejected slug at the end of the cut.

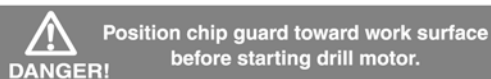

GROUNDING INSTRUCTIONS

⚠️ WARNING!

Improperly connecting the grounding wire can result in the risk of electrical shock. Check with a qualified electrician if you are in doubt as to whether the outlet is properly grounded. Do not modify the plug provided with tool. Never remove the grounding prong from the plug. If the cord or plug is damaged, have it repaired before using. If the plug will not fit the outlet, have a proper outlet installed by a qualified electrician. The Magforce must be plugged into an appropriate outlet, properly installed and grounded in accordance with all codes and ordinances. The plug and outlet should look like those in Figure A.

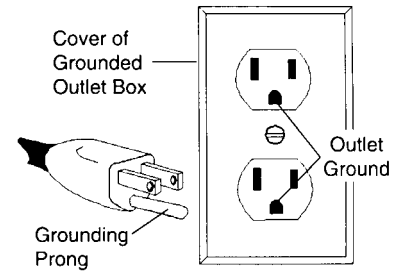

Fig. A

⚠️ WARNING!

DO NOT USE SLUGGER DRILLING MACHINES ON SURFACES OR MATERIALS BEING WELDED. DOING SO CAN RESULT IN PERSONAL INJURY AND/OR DAMAGE TO THE SLUGGER DRILLING MACHINE.

EXTENSION CORDS

Use only 3-wire extension cords that have 3-prong grounding-type plugs and 3-pole receptacles that accept the tool's plug. Replace or repair damaged cords. Make sure your extension cord is in good condition. When using an extension cord, be sure to use one heavy enough to carry the current your product will draw. An undersized cord will cause a drop in line voltage resulting in loss of power and overheating. Jancy recommends using a minimum 12 gauge extension cord not to exceed 100 feet. The table below is supplied only as a guide to minimum gauge for extension cords, where the smaller the gauge number, the heavier the cord.

MINIMUM GAUGE FOR EXTENSION CORDS				
VOLTS	TOTAL LENGTH OF CORD IN FEET			
	120V	0-25	26-50	51-100
240V	0-50	51-100	101-200	201-300
AMPERAGE				
0-6	18	16	16	14
6-10	18	16	14	12
10-12	16	16	14	12
12-16	14	12	NOT RECOMMENDED	
RECOMMENDED WIRE GAUGE				

*JANCY RECOMMENDS USING A MINIMUM 12 GAUGE EXTENSION CORD NOT TO EXCEED 100 FEET.

DRIP LOOP: To help prevent cutting fluids from traveling along power cord and contacting power source, tie a drip loop in power cord as shown in Figure B.

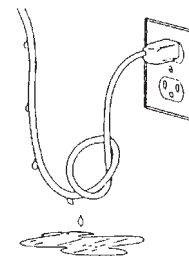

Fig. B

OPERATING INSTRUCTIONS (BEFORE YOU BEGIN)

Remove all contents from packaging and inspect to ensure no damage was incurred during shipping. Your Magforce package should also include the following:

DESCRIPTION	PART #	QTY
OPERATOR'S MANUAL	LIT107A	1
WARNING CORD LABEL	06951	1
WARRANTY CARD	0070342	1
MAGNET NOTICE WARNING	0108DOC	1
3MM HEX KEY	70586	1
SAFETY STRAP	06798	1
SAFETY AND MAINTENANCE CD	06814	1
SPOKE HANDLE ASSEMBLY	06924	1

GETTING STARTED

CAUTION!

ALWAYS DISCONNECT MAGFORCE FROM POWER SOURCE BEFORE MAKING ADJUSTMENTS

Assemble spoke handle assembly #06924 to pinion feed shaft #06206 using screw which is attached to center of drive handle. NOTE: Handle can be mounted on right or left side of machine.

WHAT YOU SHOULD KNOW BEFORE YOU DRILL

WARNING!

SMART MAGNET FUNCTION WILL STROBE MAGNET LAMP TO INDICATE INSUFFICIENT MAGNETIC ADHESION
SMART MAGNET NO LONGER INTERRUPTS MOTOR FUNCTION!

1. Type of material to be drilled, Brinnell or Rockwell hardness, material thickness and position should all be determined to ensure proper selection of Slugger cutting tools, RPM, coolant and drilling time.
2. Remove any excessive mill scale or rust from surface to be drilled.
3. Material that has been flame cut may have become heat-treated and therefore difficult to drill. Avoid drilling near such areas whenever possible.
4. Drilling with the Magforce in horizontal positions requires a special lubrication for Slugger cutters. Consult Jancy Engineering for details.

BEFORE THE CUT

1. Select correct pilot pin and place in cutter shank from the rear, align flats on cutter shank with arbor body set screws, insert cutter in arbor body.
2. Tighten set screws securely on cutter shank flats. **NOTE:** Set screws should be recessed in arbor body when tight.
3. The surface you are working on should be clean and flat, and free from rust, scale, dirt and chips.
4. Fill coolant reservoir with a water-soluble coolant.
5. Place Slugger machine on workpiece with pilot pin over the center of hole to be drilled.
6. Connect machine to power source.
7. Lower Slugger cutter to surface of material to be cut. Coolant will be released down the pilot into center of Slugger cutter. Coolant flow can be stopped by lifting pilot pin off work surface.

CAUTION!

ALWAYS USE SAFETY STRAP. FAILURE TO DO SO COULD RESULT IN PERSONAL INJURY AND/OR DAMAGE TO THE SLUGGER DRILLING MACHINE.

8. The safety strap must be securely fastened to machine and around work being drilled. Loop strap around workpiece and connect strap ends by attaching to D-rings on drill. Next, tighten safety strap by depressing thumb latch on cam buckle and pulling flat end of safety strap until excess slack is removed. **NOTE:** Safety strap is intended only to restrain the drill to the workpiece in the event of a power failure to the magnetic base.
9. Position chip guard toward work area before drilling.

READY TO MAKE THE CUT

CAUTION!

POSITION CHIP GUARD TOWARD WORK AREA BEFORE DRILLING.

1. Move magnet switch to "I" position to engage magnet. Red lamp will illuminate to indicate power is present. Magnet base should be firmly secured to workpiece at this time. **NOTE:** Thin materials may require an additional steel plate to achieve proper magnetic adhesion.
2. Start drill motor by depressing motor "I" button.
3. Using the feed handles, advance cutter into material until cutter has established an external groove in the material. During the remainder of the cut, apply smooth, constant pressure without overloading motor. **NOTE:** Slugger cutters are designed for uninterrupted cutting. Chips are evacuated during the cut. Do not peck drill when using Slugger cutters.

CAUTION!

IF DRILL MOTOR SHOULD STALL OR STOP BEFORE A COMPLETE CUT IS MADE, ALWAYS SHUT MOTOR OFF AND THEN REMOVE CUTTER FROM HOLE BEFORE ATTEMPTING TO RESTART MOTOR. FAILURE TO DO SO COULD RESULT IN PERSONAL INJURY AND/OR DAMAGE TO THE SLUGGER DRILLING MACHINE.

AFTER THE CUT

1. After Slugger cutter has finished the cut, the "slug", or uncut center portion of material, will be expelled when motor is returned to the full up position.
2. Return machine into full upright position and depress red motor "O" button. Wait until motor completely stops.
3. Move magnet switch to "O" position when ready to release magnetic base from work surface.

BASIC TROUBLESHOOTING

1. **Magnetic base not holding securely**
 - Material is too thin to engage magnet.
 - Surface of material being drilled must be free of chips, debris, rust and mill scale.
 - Does size of cutter exceed machine's rated capacity?
 - Check magnet face for unevenness, nicks and burrs.
 - Is welding equipment connected to material being drilled?
2. **Drill motor running, arbor and spindle not turning**
 - Possible sheared spindle key.
3. **Motor slows when drilling**
 - Is an extension cord being used? If so, see page 6 for recommended wire gages and cord lengths.
 - Excessive downfeed pressure during drilling cycle will cause motor to slow and overheat.
 - Does cutting tool need to be resharpened?
4. **Coolant system not working**
 - Coolant system is gravity dependent, machine must be in a upright position to operate properly.
 - Check coolant lines for blockage.
 - Dirt or debris in coolant tank.
 - Consistency of coolant mixture too thick.
 - Is correct pilot pin being used?
 - Vent hole in coolant tank lid blocked.
5. **Slugs not ejecting from cutter**
 - Lack of coolant causing slugs to expand in cutter bore.
 - Is correct pilot pin being used?
 - Possible broken internal arbor parts.
6. **Breaking cutters**
 - How is coolant being applied? Coolant must be supplied to interior of cutter.
 - Excessive feed pressure being applied when cutter initially contacts work surface.
 - Confirm material hardness.
 - Drilling stacked materials with incorrect cutter.
 - Dull cutters; dull or chipped cutting edges require excessive feed pressure, resulting in breakage.
 - Excessive arbor runout – see regular maintenance on page 10.
7. **Oversized or rough holes**
 - Insufficient coolant.
 - Excessive feed pressure.
 - Dull cutter.

REGULAR MAINTENANCE

1. Adjust spoke handle tension according to user preference. The desired tension may be obtained by turning the set screw, found on the front of the drill, left or right.
2. Keep bottom of magnet clean, free of chips, burrs, nicks, oil and other contaminants. Inspect magnet face to ensure surface is flat and square. A worn magnet surface dramatically reduces magnetic holding force.

WARNING!

**ALWAYS REMOVE CUTTER FROM DRILL BEFORE MEASURING RUNOUT.
NEVER USE HANDS OR FINGERS TO ROTATE ARBOR OR MOTOR SPINDLE.**

3. Arbor runout should not exceed .0035 inches per revolution. This is most accurately measured by placing a dial indicator needle inside of arbor bore and rotating arbor while observing indicator. **NOTE:** Always remove cutter from arbor body before measuring runout. Never use hands or fingers to rotate arbor or motor spindle.
4. Inspect motor brushes and replace as needed during extended periods of heavy machine usage.
5. Replace any worn parts and regularly tighten fasteners that have become loose during usage. **NOTE:** Never operate machine with worn or missing parts. Use only Jancy replacement parts.
6. Regularly test machine by placing machine on non-ferrous material. Engage magnet switch. Magnet adhesion warning lamp should flash.

DIMENSIONS AND SPECIFICATIONS	
Height	12"
Height (without coolant bottle)	11"
Width	6-1/2"
Length	11-1/2"
Weight	27 lbs.
Motor	1.6 HP 1200W (single phase) 120V / 10.2A ~ 240V / 5.1A 395 RPM (no load)
Arbor Bore	3/4"
Drill Point Breakaway	1096 lbs. on 1" plate
Magnet Base Dimensions	4" x 6-1/2"
Magnet Dead Lift	1810 lbs. on 1" plate
Sluggger Cutter Diameter (Maximum)	1-3/8"
Sluggger Depth of Cut (Maximum)	2"

NOTE: MAGNETIC BASE REQUIRES 1" MINIMUM MATERIAL THICKNESS WHEN DRILLING 1-1/16" AND LARGER DIAMETER HOLES

CONNECTION DIAGRAM

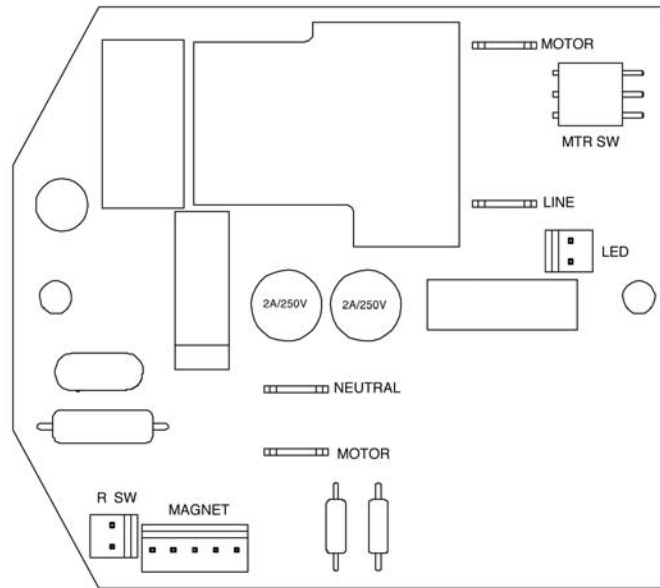

MACHINE FRAME BREAKDOWN

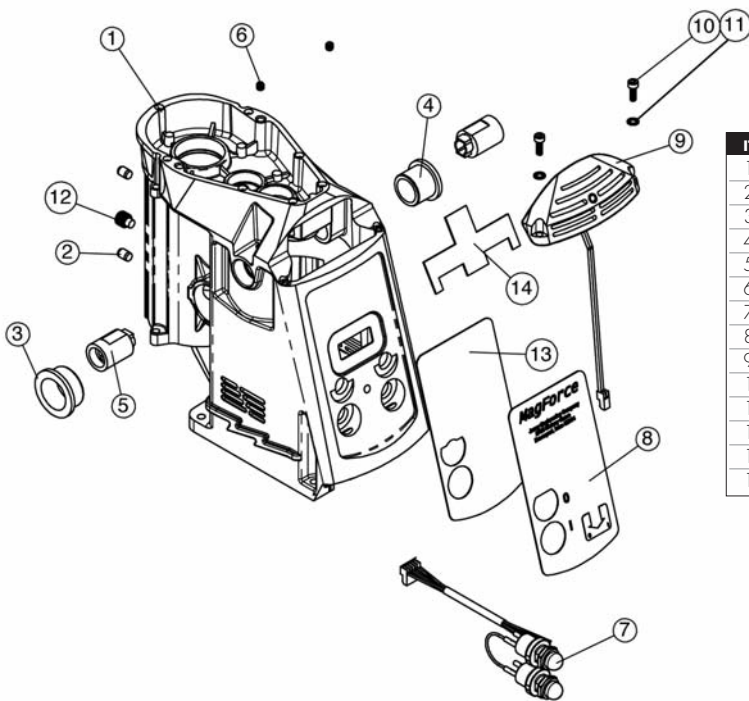

ITEM	DESCRIPTION	PART #	QTY
1	VERSION 1 FRAME WITH QUILL BUSHINGS	06302V1	1
2	PIN, DOWEL 1/4" X 3/8"	06818	2
3	BUSHING, IGLIDE M250 24MM	06742	1
4	BUSHING, IGLIDE M250 18MM	06740	1
5	BRUSH HOLDER	04551	2
6	M5 - 5 SSS	04579	2
7	VERSION 1 MOTOR SWITCHES	06962V1	1
8	MAGFORCE VERSION 1 LABEL SHEET	06403	1
9	MAGFORCE LOUVER ASSEMBLY	06938V1	1
10	SCR, SHCS M4 - .7 X 12MM DIN912	06770	2
11	WASHER, EXTERNAL M4 DIN6798	06770	2
12	SSS M10 - 1.5 X 8MM NYLON TIP	06782	1
13	LABEL PLATE	06106V1	1
14	AIR DEFLECTOR	06512	1

MACHINE BREAKDOWN

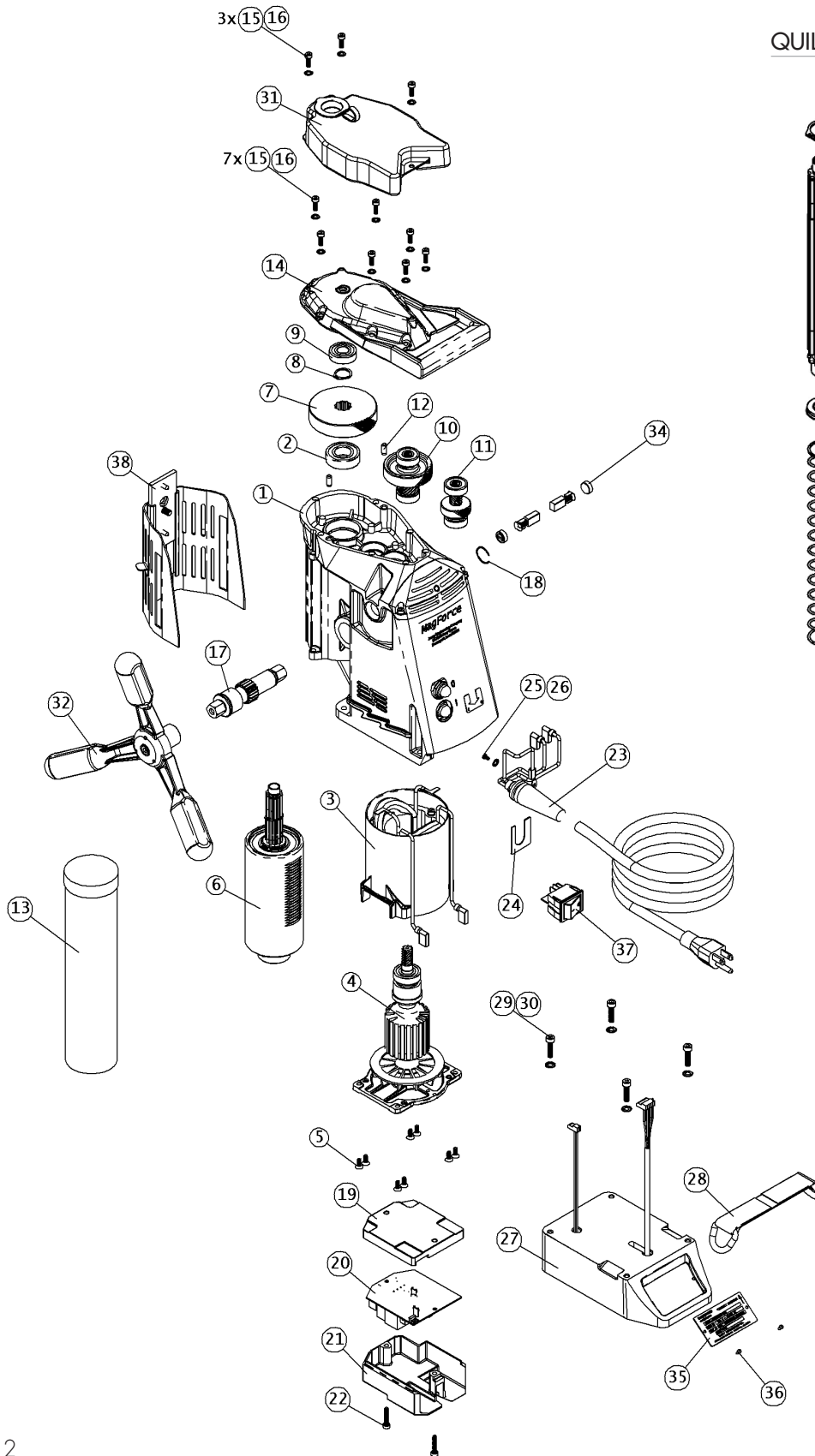

QUILL ASSEMBLY

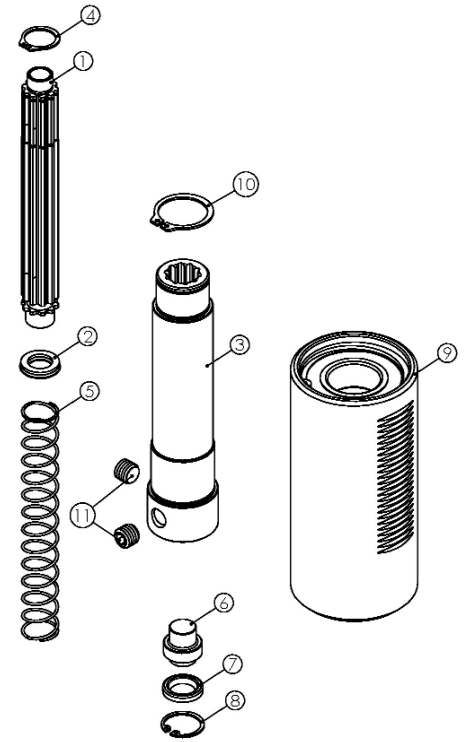

MACHINE PARTS LIST

MACHINE PARTS LIST

ITEM	DESCRIPTION	PART #	QTY
1	MAGFORCE FRAME ASSEMBLY, PUSH BUTTON	06936V1	1
2	BEARING, BALL 6003 SEALED	06710	1
3	MAGFORCE 120V FIELD ASSEMBLY	06922	1
4	MAGFORCE 120V ARMATURE ASSEMBLY	06914	1
5	SCR, FHSCS M4 - .7 X 10MM	06771	8
6	MAGFORCE QUILL ASSEMBLY	06908	1
7	GEAR, HELICAL 58X24X25 .25 LH	06802	1
8	RETAINING RING, EXTERNAL SH-62	0070015	1
9	BEARING, BALL 6001 SEALED	04543	1
10	MAGFORCE OUTPUT PINION ASSEMBLY	06910	1
11	MAGFORCE OUTPUT PINION ASSEMBLY	06912	1
12	PIN, DOWEL M5X12	06778	2
13	GREASE, LUBRIPLATE GR-132	04592-6OZ	1
14	MAGFORCE GEARCASE COVER ASSEMBLY	06944	1
15	SCR, SHCS M4 - .7 X 12MM DIN912	06770	10
16	WASHER, EXTERNAL M4 DIN6798	06773	10
17	SHAFT, PINION FEED 20X24	06206	1
18	RETAINING RING, C TYPE EXT. CE-68	06744	1
19	MAGFORCE PCB BASE	06328	1
20	VERSION 1 CIRCUIT BOARD	06550V1	1
21	VERSION 1 BOARD COVER	06330V1	1
22	SCR, SHCS M4 - .7 X 20MM	06772	2
23	MAGFORCE 120V POWER CORD ASSEMBLY	06928	1
24	RETENTION CLIP	06104	1
25	CRPHMS, M3 - .5 X 5MM	045793	1
26	WASHER, EXTERNAL M3 DIN6798	06768	1
27	MAGFORCE MAGNET ASSEMBLY	06904	1
28	SAFETY STRAP LINK	06796	1
29	SHCS, M5 - .5 X 5MM	06774	4
30	WASHER, EXTERNAL METRIC DIN6798	06781	4
31	MAGFORCE COOLANT BOTTLE ASSEMBLY	06934	1
32	SPOKE HANDLE ASSEMBLY	06924	1
33	CARBON BRUSH	06734	2
34	BRUSH CAP	06738	2
35	MOTOR TAG - 120V	06703	1
36	DRIVE SCREW, #2 X 3/16	0070028	2
37	MAGNET SWITCH	06510	1
38	MAGFORCE GUARD ASSEMBLY	06940V1	1

QUILL ASSEMBLY PARTS LIST

ITEM	DESCRIPTION	PART #	QTY
1	SPLINE DRIVE SHAFT	06210	1
2	SEAL, HYDRAULIC	06706	1
3	QUILL SHAFT	06208	1
4	RETAINING RING, EXTERNAL SH-62	0070015	1
5	ARBOR SPRING	0151431	1
6	QUILL PISTON	06212	1
7	SEAL, LIP	06704	1
8	RETAINING RING, INTERNAL HO-75	0215067	1
9*	MAGFORCE QUILL CARRIER ASSEMBLY	06906	1
10	RETAINING RING, EXTERNAL SH-98	04568	1
11	SSS M10 - 1.5 X 8MM FLAT POINT	0070545	2

*DENOTES SUB-ASSEMBLY

ARMATURE AND FIELD ASSEMBLY

ITEM	DESCRIPTION	PART #	QTY
1	MAGFORCE INSULATOR, FIELD SUPPORT	06504	1
2*	MAGFORCE FIELD ASSEMBLY	06932	1
3	SHCS, M4 - .7 X 60MM	04562	2
4	WASHER, INTERNAL M4	04576	2
5**	MAGFORCE ARMATURE ASSEMBLY	06914	1
6	ARMATURE SUPPORT BRACKET	06324	1
7	SCR, M4 X 10 FHSCS	06771	4

*USE PART# 06933 FOR 240 VOLT
 **USE PART# 06915 FOR 240 VOLT

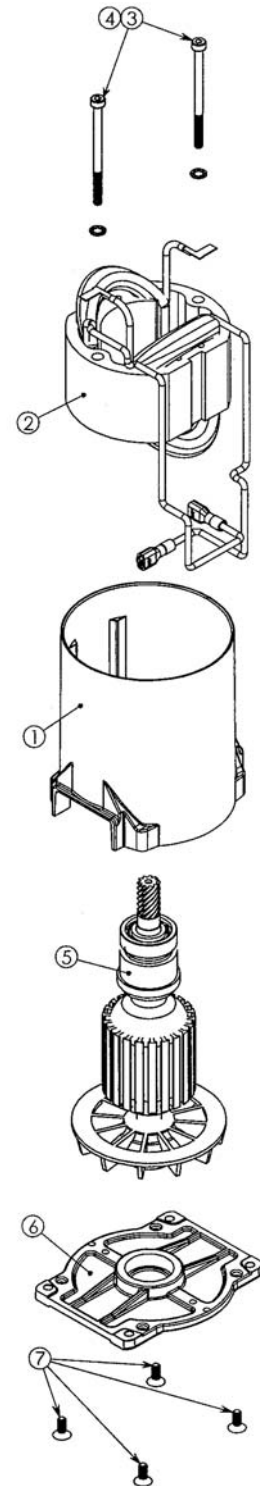

SLUGGER CUTTERS

CUTTER DIAMETER	DECIMAL EQUIVALENT	1" DEPTH CUT PART #	2" DEPTH CUT PART #	3" DEPTH CUT PART #
7/16	.4375	S4375	SL437	NA
1/2	.5000	S5000	SL500	NA
13MM	.5118	S5118	SL511	NA
14MM	.5512	S5512	SL551	NA
9/16	.5625	S5625	SL562	NA
15MM	.5906	S5906	SL590	NA
5/8	.6250	S6250	SL625	NA
16MM	.6299	S6299	SL629	NA
17MM	.6693	S6693	SL669	NA
11/16	.6875	S6875	SL687	NA
18MM	.7087	S7087	SL708	NA
19MM	.7480	S7480	SL748	NA
3/4	.7500	S7500	SL750	7500S
20MM	.7874	S7874	SL787	*7874S
13/16	.8125	S8125	SL812	8125S
21MM	.8268	S8268	SL826	*8268S
22MM	.8661	S8661	SL866	*8661S
7/8	.8750	S8750	SL875	8750S
23MM	.9055	S9055	SL905	*9055S
15/16	.9375	S9375	SL937	9375S
24MM	.9449	S9449	SL944	*9449S
25MM	.9843	S9843	SL984	*9843S
1	1.000	S1000	SL100	1000S
26MM	1.023	S1023	SL102	*1023S
1-1/16	1.062	S1062	SL106	1062S
27MM	1.063	S1063	SL107	*1063S
28MM	1.102	S1102	SL110	*1102S
1-1/8	1.125	S1125	SL112	1125S
29MM	1.141	S1141	SL114	*1141S
30MM	1.181	S1181	SL118	*1181S
1-3/16	1.187	S1187	SL119	1187S
31MM	1.220	S1220	SL122	*1220S
1-1/4	1.250	S1250	SL125	1250S
32MM	1.259	S1259	SL126	*1259S
33MM	1.299	S1299	SL129	*1299S
1-5/16	1.312	S1312	SL131	1312S
34MM	1.338	S1338	SL133	*1338S

CUTTER DIAMETER	DECIMAL EQUIVALENT	1" DEPTH CUT PART #	2" DEPTH CUT PART #	3" DEPTH CUT PART #
1-3/8	1.375	S1375	SL137	1375S
35MM	1.377	S1377	SL138	*1377S
36MM	1.417	S1417	SL141	*1417S
1-7/16	1.437	S1437	SL143	1437S
37MM	1.456	S1456	SL145	*1456S
38MM	1.496	S1496	SL149	*1496S
1-1/2	1.500	S1500	SL150	1500S
39MM	1.535	S1535	SL153	*1535S
1-9/16	1.562	S1562	SL156	1562S
40MM	1.574	S1574	SL157	*1574S
41MM	1.614	S1614	SL161	*1614S
1-5/8	1.625	S1625	SL162	1625S
42MM	1.654	S1654	SL165	*1654S
1-11/16	1.687	S1687	SL168	1687S
43MM	1.692	S1692	SL169	*1692S
44MM	1.732	S1732	SL173	*1732S
1-3/4	1.750	S1750	SL175	1750S
45MM	1.771	S1771	SL177	*1771S
46MM	1.811	S1811	SL180	*1811S
1-13/16	1.812	S1812	SL181	1812S
47MM	1.850	S1850	SL185	*1850S
1-7/8	1.875	S1875	SL187	1875S
48MM	1.889	S1889	SL188	*1889S
49MM	1.929	S1929	SL192	*1929S
1-15/16	1.937	S1937	SL193	1937S
50MM	1.968	S1968	SL196	*1968S
2	2.000	S2000	SL200	2000S
51MM	2.007	S2007	SL201	*2007S
52MM	2.047	S2047	SL204	2047S
2-1/16	2.062	S2062	SL206	2062S
2-1/8	2.125	S2125-.75S	SL212-.75S	2125S-.75S
2-3/16	2.187	S2187-.75S	SL218-.75S	2187S-.75S
2-1/4	2.250	S2250-.75S	SL225-.75S	2250S-.75S
2-5/16	2.312	S2312-.75S	SL231-.75S	2312S-.75S
2-3/8	2.375	S2375-.75S	SL237-.75S	2375S-.75S

*DENOTES NON-STOCK CUTTERS. CONSULT JANCY ENGINEERING FOR DELIVERY.
NOTE: 3-INCH DEPTH-OF-CUT SLUGGER CUTTERS ARE NOT AVAILABLE BELOW 3/4" DIAMETER.

COOLANT AND CUTTING PASTE

DESCRIPTION	PART #
PINT	10206W
QUART	10207W
GALLON	10208W
5-GALLON	10209W
55-GALLONS	10210W
CUTTING PASTE	10205

SLUGGER CUTTER PILOT PINS (FOR CUTTERS LISTED ABOVE)

PILOT FITS CUTTER SIZES	PART #
1" DEPTH OF CUT / 1/2" DIAMETER AND SMALLER	16001
2" DEPTH OF CUT / 1/2" DIAMETER AND SMALLER	16002
1" DEPTH OF CUT / 9/16" DIAMETER AND LARGER	16003
2" DEPTH OF CUT / 9/16" DIAMETER AND LARGER	16004
ALL STANDARD 3" DEPTH OF CUT	16005

OTHER AVAILABLE SLUGGER DRILLS

DESCRIPTION	MODEL #	MAX DIAMETER	CAPACITY	DEPTH
USA5 120V	18066	2-3/8"		3"
USA5 240V	18080	2-3/8"		3"
USA5 EX 120V	18066EX	2-3/8"		2"
USA5 EX 240V	18080EX	2-3/8"		2"
USA5 EXB 120V	18066EXB	2-3/8"		2"
USA5 EXB 240V	18080EXB	2-3/8"		2"
JM101 120V	19020	1-3/8"		2"
JM101 240V	19024	1-3/8"		2"
JM101 120V WITH 3/8" SLIDE BAR FEED HANDLE	19021	1-3/8"		2"
2 X 2 120V	17980	2"		2"
2 X 2 240V	17982	2"		2"
4 X 4 120V	17985	4"		3"
4 X 4 240V	17987	4"		3"
MAGFORCE 120V	06920	1-3/8"		2"
MAGFORCE 240V	06921	1-3/8"		2"
AIRFORCE	20002	1-1/16"		3/4"

YOUR DISTRIBUTOR



JANCY ENGINEERING COMPANY

MANUFACTURER OF SLUGGER® CENTERFREE CUTTERS AND PORTABLE MAGNETIC DRILLING MACHINES

Tel · 563.391.1300 or Fax · 563.391.2323

2735 Hickory Grove Road · Davenport, Iowa 52804
email · jancy@jancy.com / web · jancy.com