

HM50

PORTABLE MAGNETIC DRILLING MACHINE

- #2 Morse Taper, Versatile Multi-Purpose Machine
- 52mm Diameter Cutter Capacity

The ability to use Annular Cutters, No. 2 Morse Taper Shank Drills & Reamers, as well as a drill chuck make this a very versatile machine. Satisfying most requirements with a capacity of 52mm Diameter & 52mm Depth of cut when using Slugger cutters, and 23mm diameter using taper shank drills or reamers. An industrial 2 speed gearbox, 1100w motor and a top mounted coolant system provide a strong hardworking machine. Dual rail slide system provides rigidity and eliminates the need for gib adjustments. Handles can be easily changed from left to right hand operation. Suitable for steel fabrication, engineering workshops and maintenance facilities where a versatile machine is highly beneficial.



The HM50 Accepts #2 Morse Taper Bits & an Optional 13mm Drill Chuck & Arbor is also Available for use with Standard Drill Bits

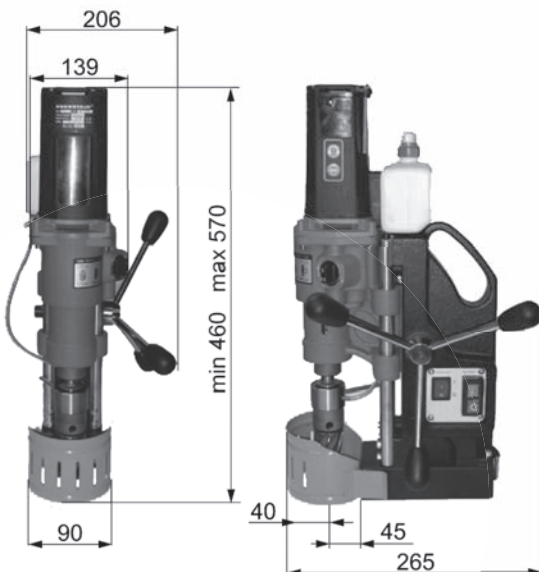

TECHNICAL INFORMATION

Part No.	HM50
Capacity (Diameter)	52mm
Capacity (Depth)	52mm
Capacity (Twist Drills)	#2 Morse Taper 23mm
Motor	1100watt Single Phase
Gearbox	2 Speed 180 / 360rpm
Weight	16.7kg
Magnetic Dead Lift	11800nm on 25mm Steel Plate
Height (min / max)	460mm / 570mm

Incorporated Through Spindle Coolant System

Supplied In Metal Carry Case with Cutter Arbor, Guard & Safety Strap



Local Dealer