

Magnetic Drilling Machines

Slugger
BY JANCY ENGINEERING USA

Holemaker
QUALITY EUROPEAN MADE MAGNETIC DRILLING MACHINES

With more than 25 years on the Australian Market, The 'Slugger' brand name has a proven reputation for High Quality, Reliable, Robust and Durable Machines & Cutters. Customers can also be confident with ongoing backup service. Our extensive range of machines, cutters & accessories enable Slugger products to be used in a diverse range of applications.

FOR A QUICK COMPARISON OF THE FULL RANGE PLEASE VIEW THE MAGNETIC DRILLING MACHINE SELECTION CHART ON PAGE 8

Holemaker 30

Lightweight & Compact,
Fully Featured Machine

CUTTER CAPACITY
30 mm

12 mm
TWIST DRILL CAPACITY

Featuring a powerful dual coil magnet and 920Watt Industrial motor. The HM30's low profile, integrated coolant system and the ability to quickly change the feed handles to left or right hand operation make this machine ideal for working in confined spaces. Dual rail slide system provides rigidity and eliminates the need for gib adjustments.

*12mm twist drill capacity using Weldon shank twist drill bits.

Optional Accessories & Consumables



Weldon Shank Twist Drills - pg16



Slugger Cutters - pg12

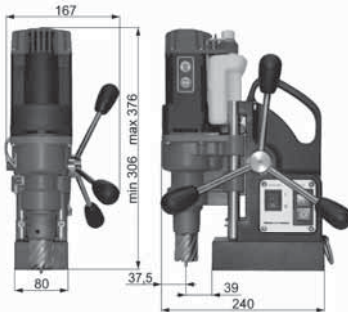

Part Number	HM30
Capacity (Diameter)	30mm
Capacity (Depth)	52mm
Motor Power	920Watt
Input Power	1010Watt Single Phase 240V
Speed	350rpm
Weight	10.5kg
Magnetic Dead Lift	9500N-m on 25mm Steel Plate
Height (min / max)	306 / 376mm
Incorporated Through Spindle Coolant System	
Smart Magnet Technology to ensure sufficient Magnetic Adhesion	
Supplied In Metal Carry Case with Cutter Guard & Safety Strap	

Holemaker 40

Economical & Versatile Machine

CUTTER CAPACITY
40 mm

13 mm
TWIST DRILL CAPACITY

Featuring an 1100watt Motor, Powerful Dual Coil Magnet, Capacity of 40mm Diameter & 52mm Depth of Cut. Available with the option of a Quick Grip arbor for fast tool-less cutter changing, or a conventional grub screw arbor. The ability to easily accept twist drills up to 13mm *using the optional chuck & adaptor, makes this a versatile machine.

Through cutter coolant feed, with an external side mounted coolant tank ensures smooth fast clean hole cutting. With all the above features in a high quality, compact, lightweight, durable machine, the Holemaker 40 is Exceptional Value for Money.



Optional Accessories & Consumables



Drill Chuck - pg11



Slugger Cutters - pg12

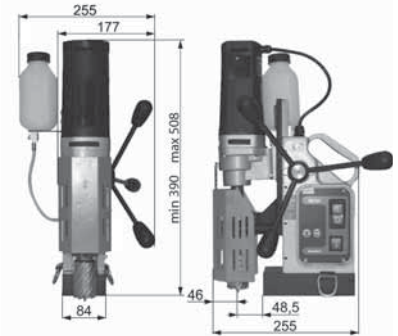

Part Number	HM40 (with Quick Grip arbor) HM40GS (with Grub Screw arbor)
Capacity (Diameter)	40mm
Capacity (Depth)	52mm
Motor Power	1020Watt
Input Power	1100Watt Single Phase 240V
Speed	440rpm
Weight	13.7kg
Magnetic Dead Lift	10650N-m on 25mm Steel Plate
Height (min / max)	390 / 508mm
Incorporated Through Spindle Coolant System	
Smart Magnet Technology to ensure sufficient Magnetic Adhesion	
Supplied In Metal Carry Case with Cutter Guard & Safety Strap	

Holemaker 40 Gear Reduction

With all the features of the Holemaker 40, this unit has the unique feature of Gear Reduction on the down feed which makes for smoother hole cutting & ease of operation. Ideal for drilling harder materials.



Part Number	Description
HM40GR	Holemaker 40 Magnetic Drilling Machine with Gear Reduction on the Downfeed