

Magnetic Drilling Machines

FOR A QUICK COMPARISON OF THE FULL RANGE PLEASE VIEW THE MAGNETIC DRILLING MACHINE SELECTION CHART ON PAGE 8



Holemaker 40AD

Low Profile Angle Drive Drilling Machine



A Low profile angle drive machine providing a constant working height of 181mm. The HM40AD utilises standard Sluggers Cutters, ensuring a wide range of cutters are always available. The feed handle can be easily changed to either side or removed for use with a socket wrench on the hex drive. Coolant is supplied to the cutter through the spindle by attaching the remote coolant feed bottle.

*12mm twist drill capacity using Weldon shank twist drill bits.



Optional Accessories & Consumables



Weldon Shank Twist Drills - pg16



Sluggers Cutters - pg12

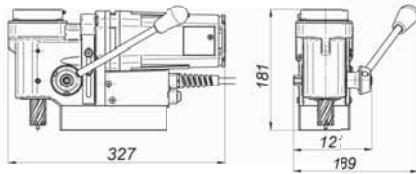

Holemaker 50

#2 Morse Taper, Versatile Multi-Purpose Machine



The ability to use Sluggers Cutters, No. 2 Morse Taper Shank Drills & Reamers, as well as a drill chuck makes this a very versatile machine. Satisfying most requirements with a capacity of 52mm Diameter & 52mm Depth of cut when using Sluggers cutters, and 23mm diameter using taper shank drills or reamers. An industrial 2 speed gearbox and 1100w motor provide a strong hardworking machine. Dual rail slide system provides rigidity and eliminates the need for gib adjustments. Handles can be easily changed from left to right hand operation. Top mounted coolant system. Available with the option of a Quick Grip arbor for fast tool-less cutter changing, or a conventional grub screw arbor. Suitable for steel fabrication, engineering workshops & maintenance facilities where a versatile machine is highly beneficial.



Optional Accessories & Consumables



Drill Chuck - pg11



Sluggers Cutters - pg12



Taper Shank Drills pg17

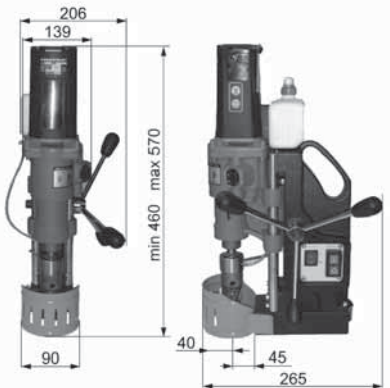

Part Number	HM40AD
Capacity (Diameter)	40mm
Capacity (Depth)	25mm
Motor Power	1020Watt
Input Power	1100Watt Single Phase 240V
Speed	310rpm
Weight	11.1kg
Magnetic Dead Lift	9500N-m on 25mm Steel Plate
Height (min / max)	181mm Constant Working Height
Incorporated Through Spindle Coolant System using remote bottle.	
Supplied In Metal Carry Case.	

Part Number	HM50 (with Quick Grip arbor) HM50GS (with Grub Screw arbor)
Capacity (Diameter)	52mm
Capacity (Depth)	52mm
Capacity (Twist Drills)	#2 Morse Taper 23mm
Motor Power	1080Watt
Input Power	1200Watt Single Phase 240V
Speed	2 Speed 180 / 360rpm
Weight	16.7kg
Magnetic Dead Lift	11800N-m on 25mm Steel Plate
Height (min / max)	460mm / 570mm
Incorporated Through Spindle Coolant System.	
Smart Magnet Technology to ensure sufficient Magnetic Adhesion.	
Supplied In Metal Carry Case with Cutter Guard & Safety Strap.	