

Magnetic Drilling Machines

FOR A QUICK COMPARISON OF THE FULL RANGE PLEASE VIEW THE MAGNETIC DRILLING MACHINE SELECTION CHART ON PAGE 8



Slugger USA101

Extra Heavy Duty Compact Machine



The USA101 is a lightweight, robust performer built to last and is ideal for everyday use. Accepts Slugger cutters up to 35mm diameter and 52mm depth of cut. Powerful motor with cast aluminum housing. Through spindle coolant system with a unique coolant bottle that attaches firmly to the machine with a magnet, and can be easily removed and attached to the workpiece, allowing coolant feed whilst drilling in vertical positions. Handles can be easily changed from left to right hand operation.

*13mm twist drill bit capacity using the optional chuck & adaptor.

Optional Accessories & Consumables



Drill Chuck - pg11



Slugger Cutters - pg12

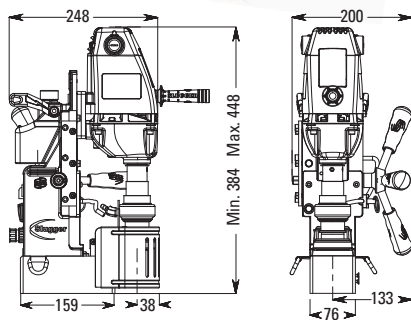

Slugger Magforce

Revolutionary Ultra Compact Constant Working Height Machine



The ultra compact design & hole capacity of 40mm x 52mm, allows the Magforce to be utilised in areas not possible with any other machine. Featuring a 285mm constant working height and weighing only 12kg, the Magforce is perfect for drilling vertical, horizontal or upside down in extremely tight spots. Left or right hand operation. Internal Coolant / Positive Slug Ejection. 1200watt high torque motor.

*12mm twist drill capacity using Weldon shank twist drill bits.



Optional Accessories & Consumables



Weldon Shank Twist Drills - pg16



Slugger Cutters - pg12

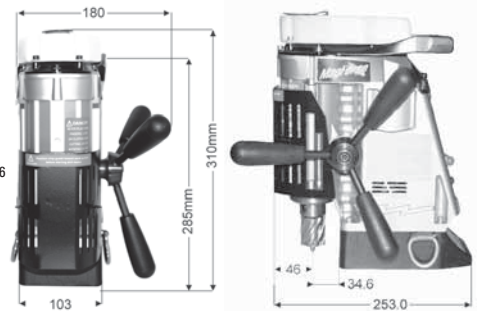

Part Number	MFV1
Capacity (Diameter)	40mm
Capacity (Depth)	52mm
Motor Power	1200Watt
Input Power	1435Watt Single Phase 240V
Speed	395rpm
Weight	12.0kg
Magnetic Dead Lift	8000N-m on 25mm Steel Plate
Height (min / max)	285mm without fluid tank 310mm with fluid tank
Incorporated Through Spindle Coolant System.	
Smart Magnet Technology with warning light for insufficient Magnetic Adhesion.	
Supplied In Moulded Carry Case with Cutter Guard & Safety Strap.	



Part Number	USA101
Capacity (Diameter)	35mm
Capacity (Depth)	52mm
Motor Power	1380Watt
Input Power	1575Watt Single Phase 240V
Speed	450rpm
Weight	13.15kg
Magnetic Dead Lift	6580N-m on 25mm Steel Plate
Height (min / max)	384mm / 448mm
Incorporated Through Spindle Coolant System.	
Smart Magnet Technology with warning light for insufficient Magnetic Adhesion.	
Supplied In Moulded Carry Case with Cutter Guard & Safety Strap.	