

# Magnetic Drilling Machines

FOR A QUICK COMPARISON OF THE FULL RANGE PLEASE VIEW THE MAGNETIC DRILLING MACHINE SELECTION CHART ON PAGE 8



## Slugger Max 2x2 Heavy Duty #2 Morse Taper Machine



Versatility is the hallmark of this machine. Holes up to 52mm diameter by 52mm depth can be produced quickly and efficiently using Slugger cutters, and with the No 2 Morse Taper it is just at home with a Drill Chuck & Arbor or Taper Shank Drills and Reamers up to 23mm. Featuring a Heavy Duty 2 speed gear box and side mounted coolant system. This machine is perfectly suited to engineering workshops & maintenance facilities, where its versatility is most valuable.

### Optional Accessories & Consumables



Drill Chuck - pg11



Slugger Cutters - pg12



Taper Shank Drills pg17

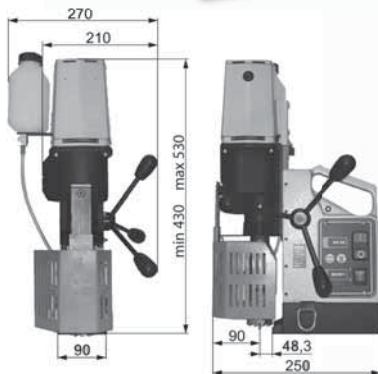

Part Number	SM2X2-MT2
Capacity ( Diameter )	52mm
Capacity ( Depth )	52mm
Capacity ( Twist Drills )	#2 Morse Taper 23mm
Motor Power	1200Watt
Input Power	1380Watt Single Phase 240V
Speed	2 Speed 210 / 420rpm
Weight	17.0kg
Magnetic Dead Lift	12000N-m on 25mm Steel Plate
Height ( min / max )	430mm / 530mm
<b>Incorporated Through Spindle Coolant System</b>	
Smart Magnet Technology to ensure sufficient Magnetic Adhesion	
Supplied In Metal Carry Case with Cutter Guard & Safety Strap	

## Slugger USA5000

Heavy Duty Workhorse,  
Powerful & Robust



Powerful & Rugged 1400 watt motor with 2 speed gearbox & high density dual coil magnet providing optimum cutting performance. Holes up to 60mm diameter by 75mm depth can be produced quickly and efficiently. Coolant tank housed within machine frame for protection. Coolant level easily visible. Easy & precise adjustment of slides by single screw on Gib Bar. Perfect for Steel Fabrication shops requiring a heavy duty workhorse drill, Powerful & robust.

\*19mm twist drill bit capacity using the optional chuck & adaptor.

### Optional Accessories & Consumables



Drill Chuck - pg11



Slugger Cutters - pg12

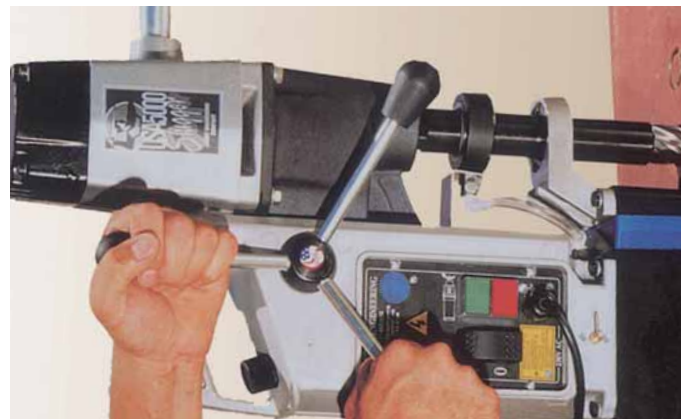
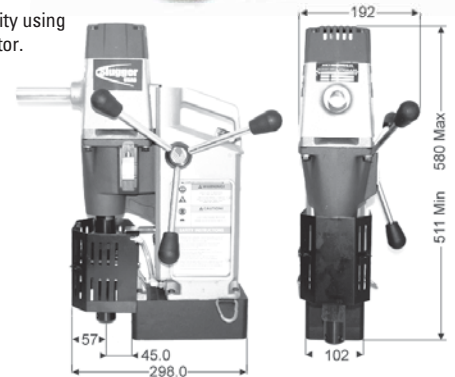

Part Number	USA5000EX
Capacity ( Diameter )	60mm
Capacity ( Depth )	75mm
Capacity ( Twist Drills )	19mm With Optional Chuck
Motor Power	1400Watt
Input Power	1580Watt Single Phase 240V
Speed	2 Speed 270 / 520rpm
Weight	21.8kg
Magnetic Dead Lift	15000N-m on 25mm Steel Plate
Height ( min / max )	511mm / 580mm
<b>Incorporated Through Spindle Coolant System</b>	
Smart Magnet Technology to ensure sufficient Magnetic Adhesion	
Overload warning light to advise excessive load	
Supplied In Moulded Carry Case with Cutter Guard & Safety Strap	