

Magnetic Drilling Machines

FOR A QUICK COMPARISON OF THE FULL RANGE PLEASE VIEW THE MAGNETIC DRILLING MACHINE SELECTION CHART ON PAGE 8

Slugger
BY JANCY ENGINEERING USA

Holemaker
QUALITY EUROPEAN MADE MAGNETIC DRILLING MACHINES

Slugger Max 3x3

#3 Morse Taper Variable Speed Machine



No 3 Morse Taper Drilling Machine Accepts Slugger Cutters, No. 3MT Drill Bits, Tapping Head & Reamers. Two speed gearbox with soft start, variable speed motor and jog reverse function, making this machine ideal for tapping. 75mm diameter x 75mm depth Slugger Cutter Capacity. Side mounted coolant system. Optional 1L pressure feed coolant bottle available.

Optional Accessories & Consumables



Drill Chuck - pg11



Slugger Cutters - pg12



Taper Shank Drills pg17



Tapping Head - pg11

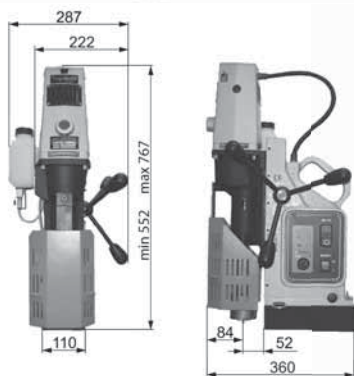

Slugger Max 4x4

#3 Morse Taper Large Capacity Machine



Retaining the largest hole-making capacity of all stocked Slugger drills, the SM4X4 is capable of producing burr-free holes up to 110mm diameter by 100mm depth. 1800w motor with 4-speed mechanical gearbox produces superb torque through gear reduction in low speeds. #3 morse taper spindle bore for use with tapered shank drills. Supplied complete with side mounted coolant system and arbor for use with 3/4" shank Slugger Cutters up to 75mm diameter by 75mm depth of cut. Optional arbor to take 1-1/4" shank cutters up to 110mm diameter by 100mm depth, 1L pressure feed coolant bottle available.



Optional Accessories & Consumables



Drill Chuck - pg11



Slugger Cutters - pg12



Taper Shank Drills pg17

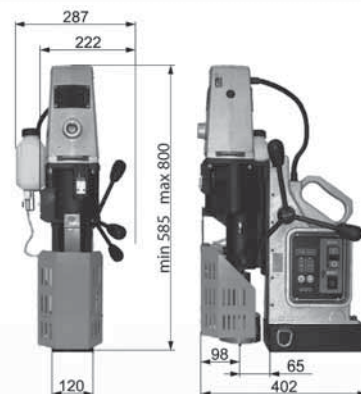

Part Number	SM3X3
Capacity (Diameter)	75mm
Capacity (Depth)	75mm
Capacity (Twist Drills)	#3 Morse Taper 32mm
Motor Power	1400Watt
Input Power	1570Watt Single Phase 240V
Speed	2 Speed Variable Gearbox with Reverse & Soft Start Function 80-160 / 160-320rpm
Weight	28.0kg
Magnetic Dead Lift	19500N-m on 25mm Steel Plate
Height (min / max)	552mm / 767mm
Incorporated Through Spindle Coolant System	
Overload warning light to advise excessive load	
Supplied In Heavy Duty Metal Carry Case	

Part Number	SM4X4
Capacity (Diameter)	110mm
Capacity (Depth)	100mm
Capacity (Twist Drills)	#3 Morse Taper 32mm
Motor Power	1800Watt
Input Power	1990Watt Single Phase 240V
Speed	4 Speed Heavy Duty Gearbox 100 / 150 / 200 / 310rpm
Weight	33.0kg
Magnetic Dead Lift	22000N-m on 25mm Steel Plate
Height (min / max)	585mm / 800mm
Incorporated Through Spindle Coolant System	
Overload warning light to advise excessive load	
Supplied In Heavy Duty Metal Carry Case	